

Energy System analysis – assessment of the contribution of RES under different evolutions/scenarios of the Kazakhstan energy system

Nadezhda Sagadatova
Aidos Satan



Objective:

To analyse how renewable energy can contribute to the future electricity system under different development pathways of the country's energy system.

The study aims to:

- Assess the role of renewable energy in meeting future electricity demand.
- Compare alternative system evolution pathways in a consistent analytical framework.
- Evaluate system impacts in terms of cost, emissions, reliability, and flexibility.
- Identify key drivers and constraints for renewable energy integration.
- Support evidence-based energy planning and policy discussions.

What Questions this study aims to answer

- How does the power system evolve under different policy and technology assumptions?
- What options, in terms of energy resources, would be available for Kazakhstan to meet its long-term energy requirement?
- What options would be useful to reduce the negative impacts of energy activities on the environment?
- What level of renewable energy penetration is achievable in each pathway?
- How do system costs and emissions change across scenarios?

Model Scope

- Optimisation-based electricity system model
- 14 oblast-level zones
- Hourly resolution
- 2026–2060 horizon

Constraints

- Demand balance at all hours
- Capacity and availability limits
- Network limits
- Policy constraints

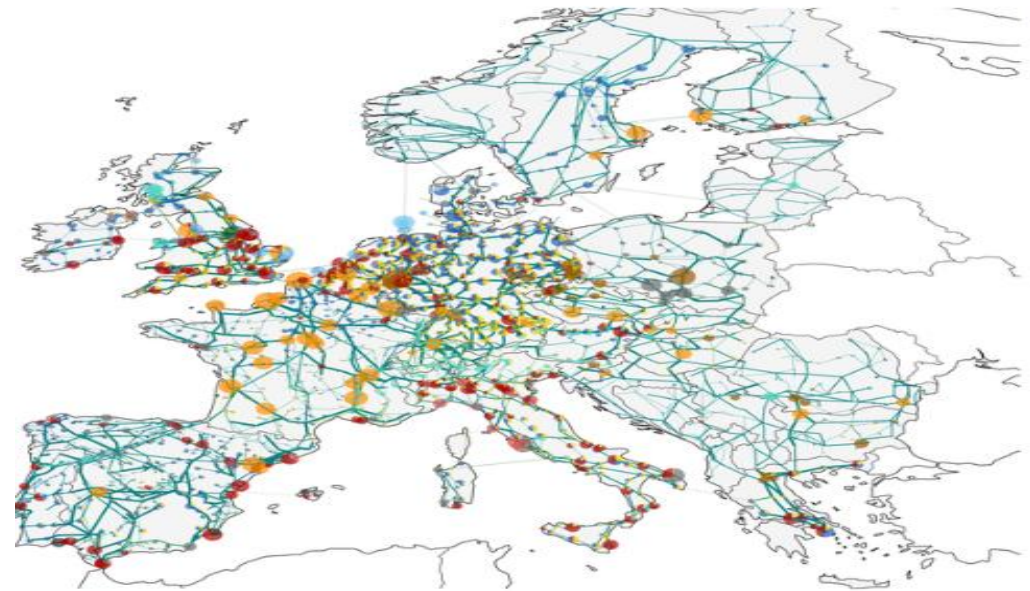

Technology coverage

- Coal, gas (CCGT, OCGT)
- Hydro, Solar PV, onshore wind, Nuclear (in relevant scenarios)
- Battery storage
- Transmission network & Cross-border trade links

Typical Components of a PyPSA Model

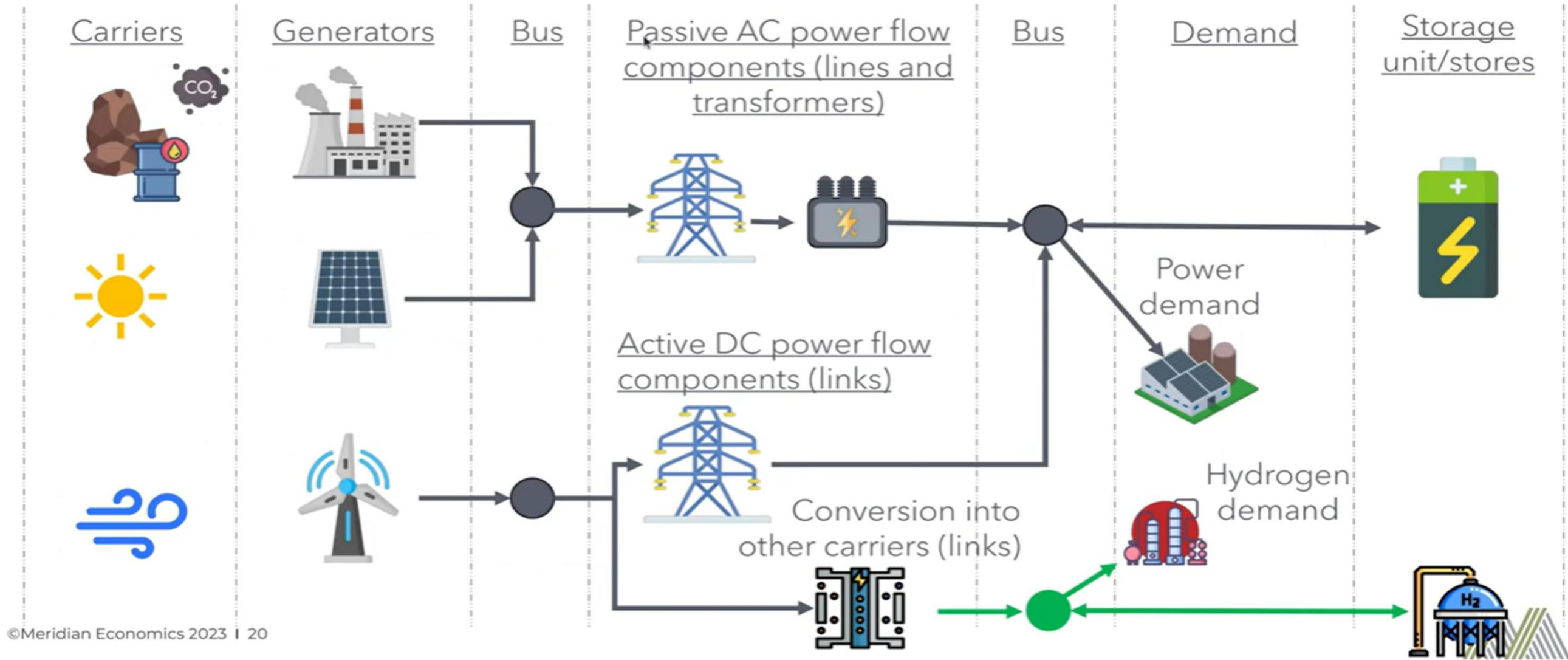

©Meridian Economics 2023 | 20

Renewable Energy share target
15% by 2030



Paris Agreement:
Carbon Neutrality
by 2060



Nuclear Power Plant
construction: 2035-
2040 - 2400 MW



Reference

Continuation of current trajectory with no new major policy interventions; serves as the reference case for costs, emissions, and risks.

REnewable Target

Short-/medium-term stress test: checks if 2030 RES objectives can be achieved with acceptable costs or stability issues.

Nuclear introduction

Evaluates nuclear as firm low-carbon baseload after 2035 and its system effect.



Net zero emission by 2060

Explores a credible pathway consistent with carbon neutrality by 2060, requiring large-scale RES, flexibility, and potentially grid reinforcement under a CO₂ constraint.

Reference

Continuation of current trajectory with no new major policy interventions; serves as the reference case for costs, emissions, and risks.

REnewable Target

Short-/medium-term stress test: checks if 2030 RES objectives can be achieved with acceptable costs or stability issues.

Nuclear introduction

Evaluates nuclear as firm low-carbon baseload after 2035 and its system effect.

Net zero emission by 2060

Explores a credible pathway consistent with carbon neutrality by 2060, requiring large-scale RES, flexibility, and potentially grid reinforcement under a CO₂ constraint.

Baseline Demand

Scenario adopted demand

1

NETWORK TOPOLOGY

14 oblast buses (nodes), same baseline topology and interconnections, no connection is considered with neighbor countries (no export/import)

2

EXISTING PLANTS

existing plants are represented explicitly; by default they operate within technical limits and retire at end-of-life unless a scenario changes retirement rules.

3

LOAD DATASET

one common hourly load demand projected till 2060

4

MODELLING FRAMEWORK

cost-minimising optimisation of investments + dispatch

4

WEATHER DATA

weather profile for 2024 was extracted and used for all years as a reference to generate RE profiles

Represents continuation of current policy and market trends without additional climate or renewable mandates.

Main assumptions

- No CO₂ emission limits
- No renewable share targets
- No forced technology shares
- Nuclear not allowed
- Existing coal plants operate until technical retirement
- New investments selected purely by least-cost optimisation
- Gas and renewables compete economically
- Reliability ensured via adequacy constraints (reserve margin)

Key modelling logic

- The system minimises total system cost while meeting demand and adequacy.
- Renewables grow where they are cost-competitive.
- Coal continues operating if it remains economically viable.
- Gas provides flexibility and peak capacity.
- Storage is built only if economically justified.

How fast renewables grow on pure economics

How long coal remains competitive

What the natural cost-optimal transition path looks like

Represents Kazakhstan following explicit renewable electricity targets.

Main assumptions

- Minimum renewable generation share in each period
- Renewables extendable candidates: solar, wind
- Nuclear excluded
- Gas Plants allowed to be extendable
- No CO₂ cap

Key modelling logic

- Renewable generation share is enforced via a constraint.
- The system chooses the cheapest combination of energy mix by reaching the target RE share

How expensive renewable targets are
Which technologies dominate renewable growth
Whether gas remains important

Represents Kazakhstan's government decision to construct a nuclear power plant and integrate it into the power system.

Main assumptions

- Nuclear plant is mandatorily built
- Nuclear capacity fixed at 2.4 GW from 2040
- Nuclear operates according to technical constraints (baseload behaviour)
- No CO₂ constraint
- No renewable target
- Nuclear does not compete for entry, only for dispatch
- Other technologies compete around nuclear

Key modelling logic

- Nuclear capacity is exogenously imposed.
- The optimisation determines:
 - How much nuclear actually generates
 - Which technologies it displaces
 - Its impact on costs and emissions

- 
- **How much electricity will nuclear actually generate once built**
 - **Which technologies does nuclear mainly replace (coal, gas, or renewables)**
 - **How much does nuclear reduce CO₂ emissions**
 - **How does nuclear affect total system cost**

Represents Kazakhstan committing to near-zero power-sector emissions by 2060.

Main assumptions

- Absolute CO₂ emission caps:
 - 2040: 100 Mt
 - 2050: 20 Mt
 - 2060: 1 Mt
- Nuclear allowed
- Gas allowed but constrained by CO₂
- No forced technology shares

Key modelling logic

- CO₂ cap is binding.
- The system must find least-cost way to decarbonise.
- Nuclear, renewables, storage, and gas compete under CO₂ pressure.

- How difficult carbon neutrality is
- Which technologies dominate
- How system structure changes
- What is the cost to reach Carbon Neutrality target

Input #1

Load Projection: hourly load projection based on studies of annual load projection

Input #1b

Load Projection: special separate load for Net Zero Emission Scenario

Input #2

Weather Data: used to generate RE profiles

Input #3

Existing Power Plant list with installed capacity, retirement period and etc

Assumption #1

Model is single region, without neighbor country connection

Assumption #2

14 nodes. 1 for each oblast/region.

Assumption #3

Regional load disaggregation will the same current load share

Assumption #4

Investment periods: 2026, 2030, 2050

Assumption #5

No new coal capacity in any scenario.

Assumption #6

Seasonal load profiles(patterns) will not change in the future

Input#1: Load Projection

Data taken from 'vervestacks.cloud' from 2020 till 2050. It was extended till 2060 with the same 5 year step following the same rate decline

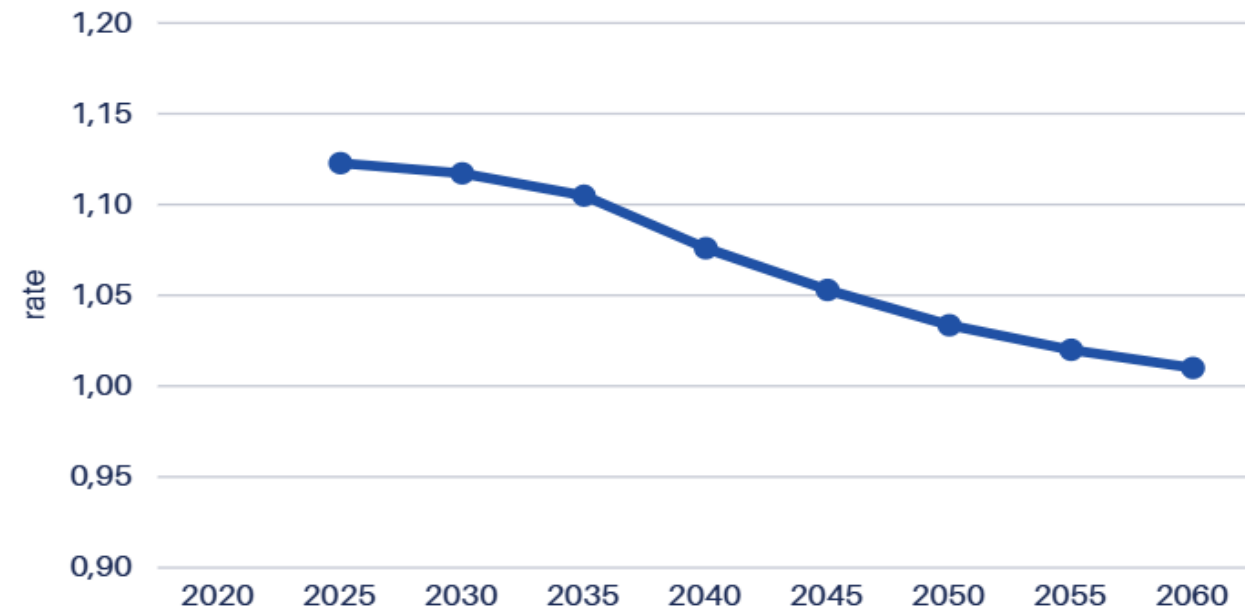
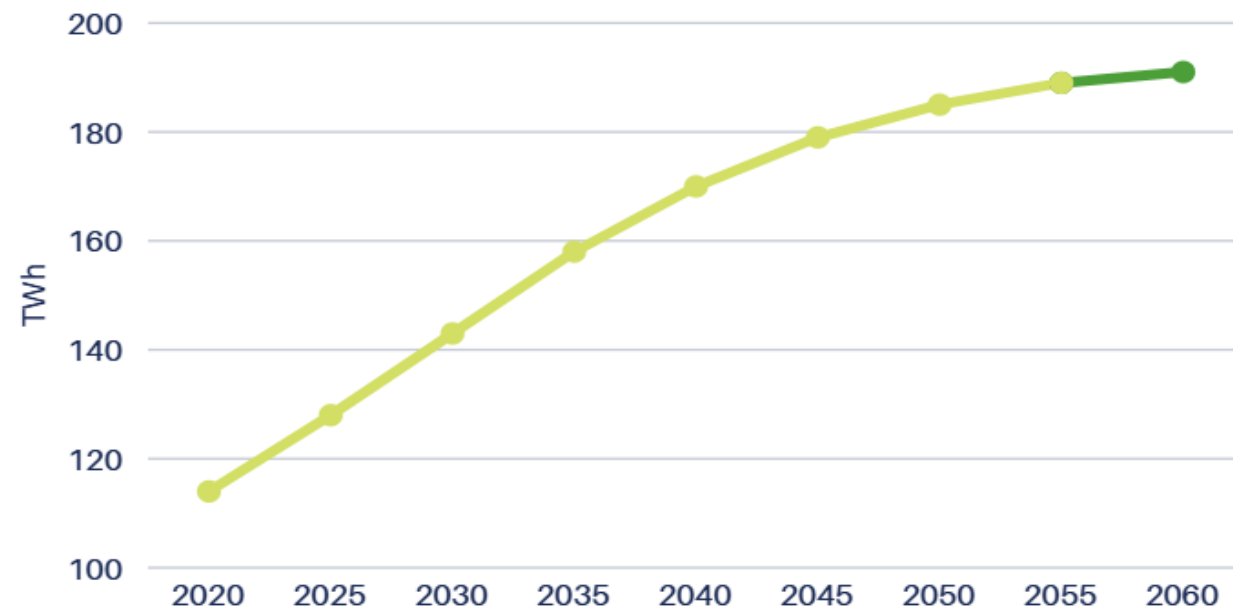

190.6 TWh

in 2060

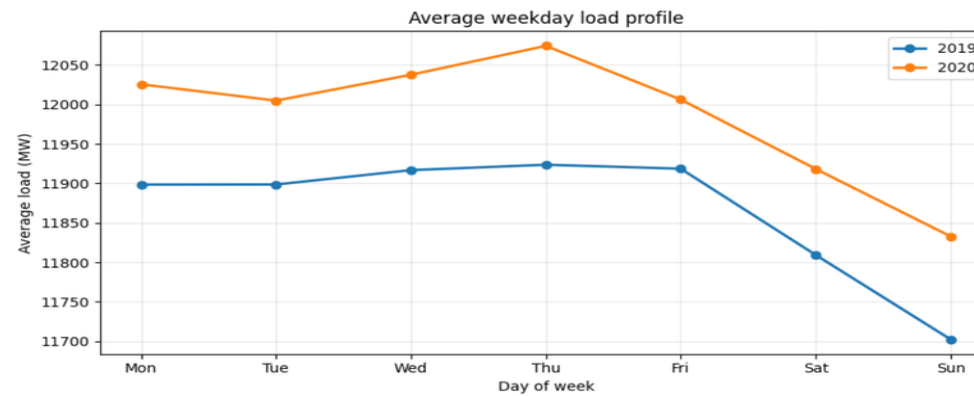
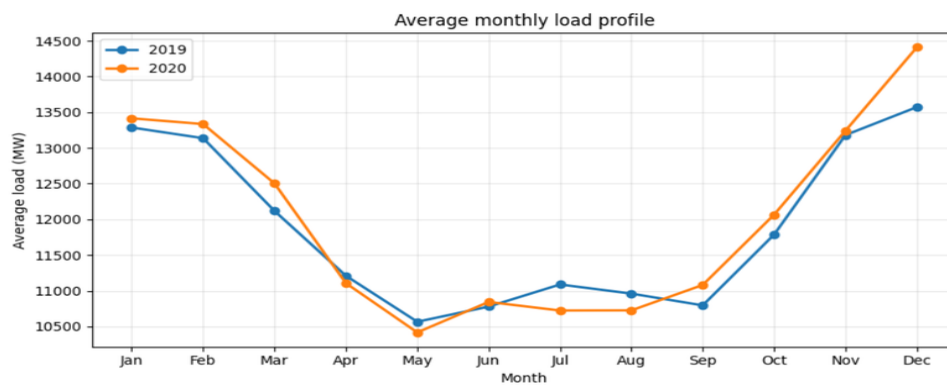
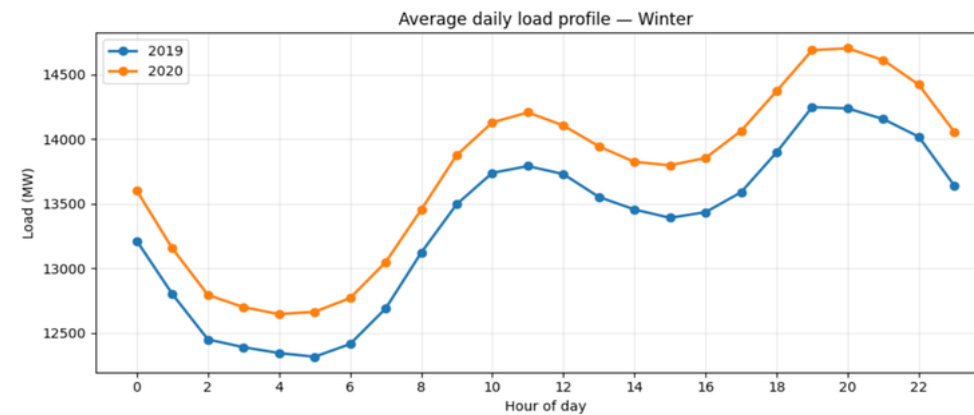
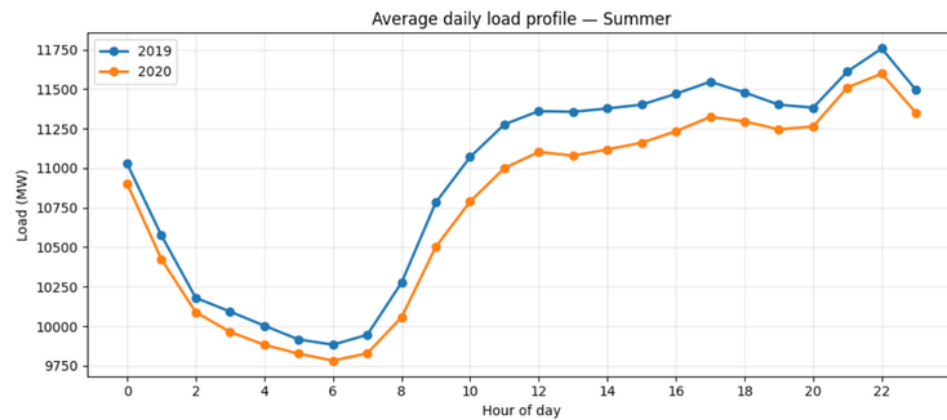
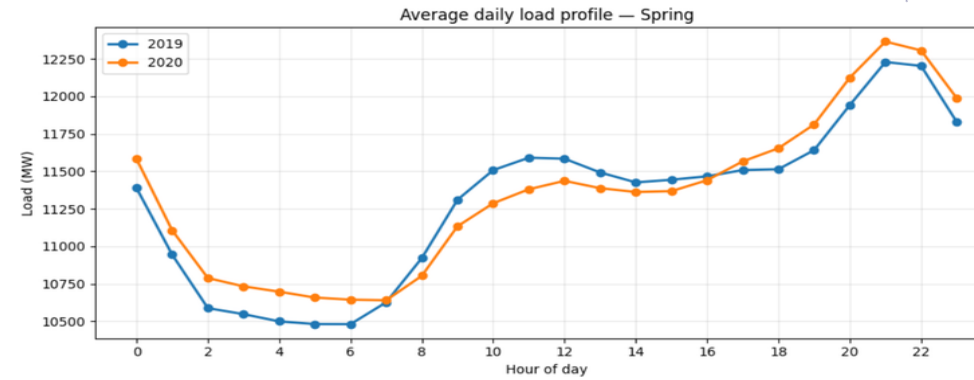
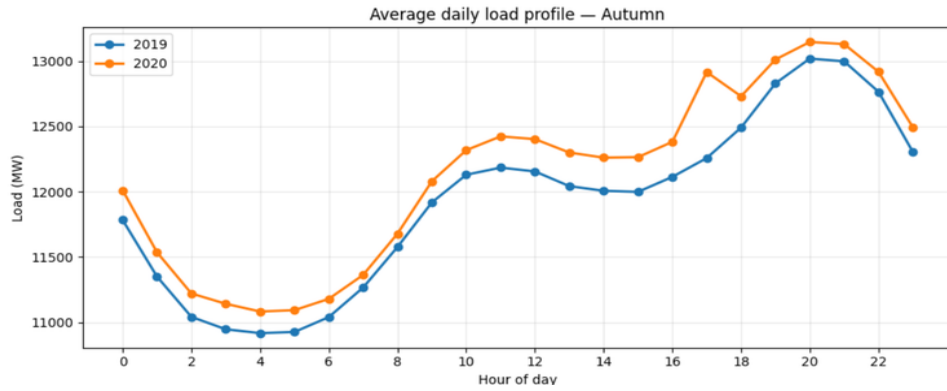

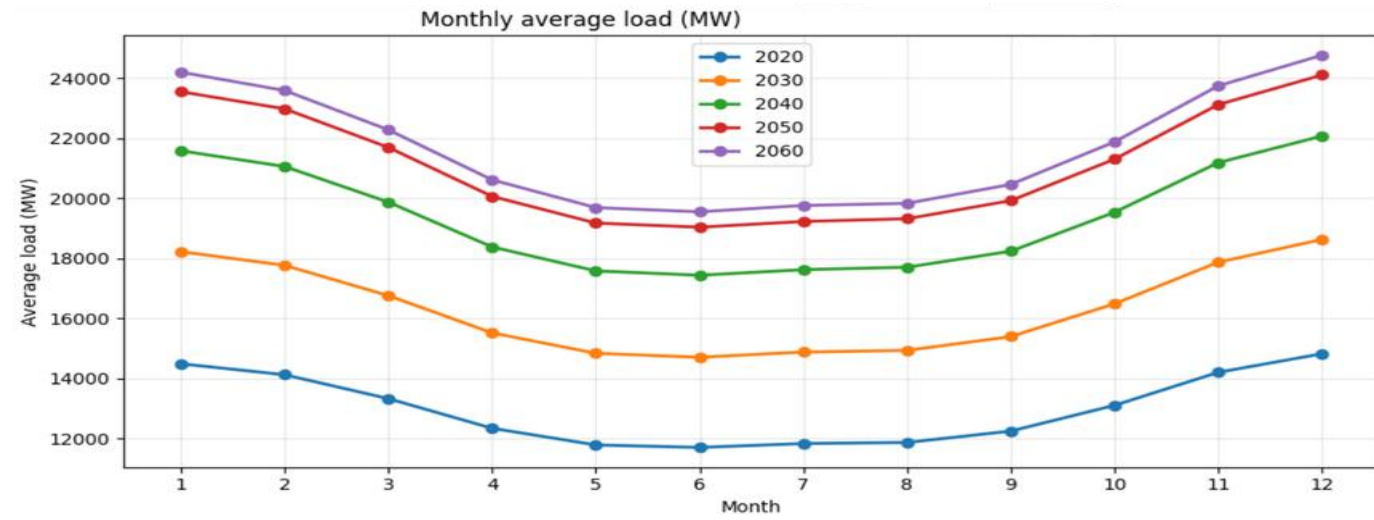
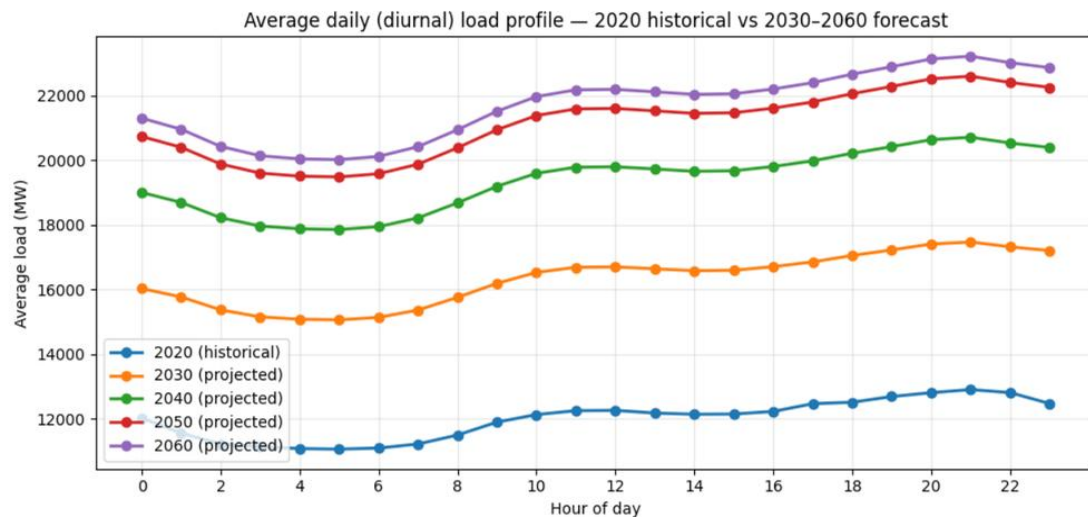
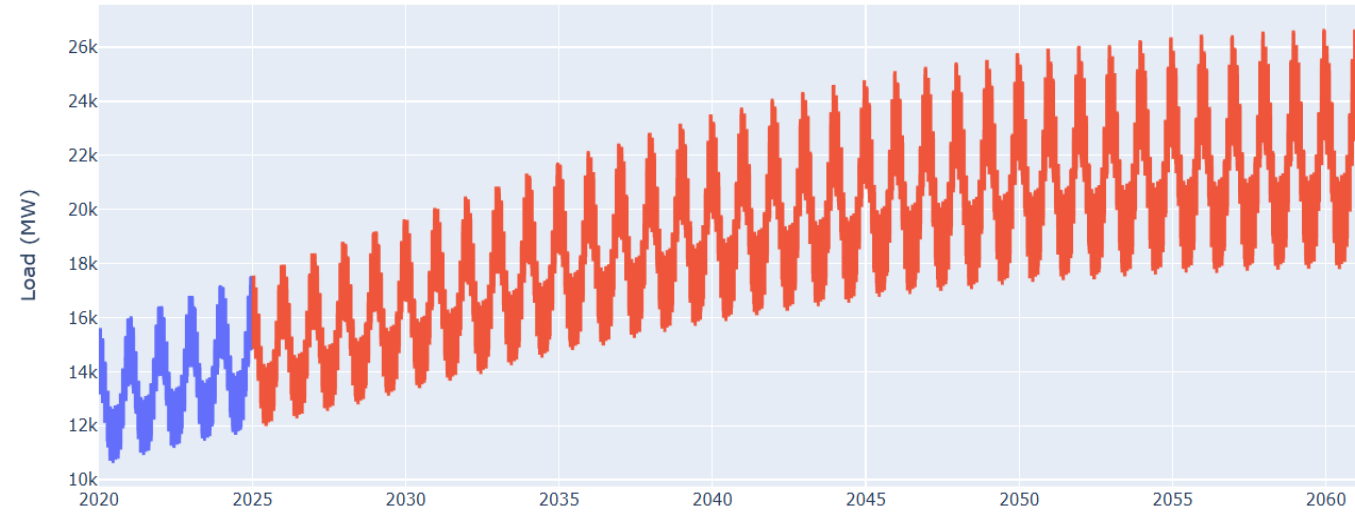
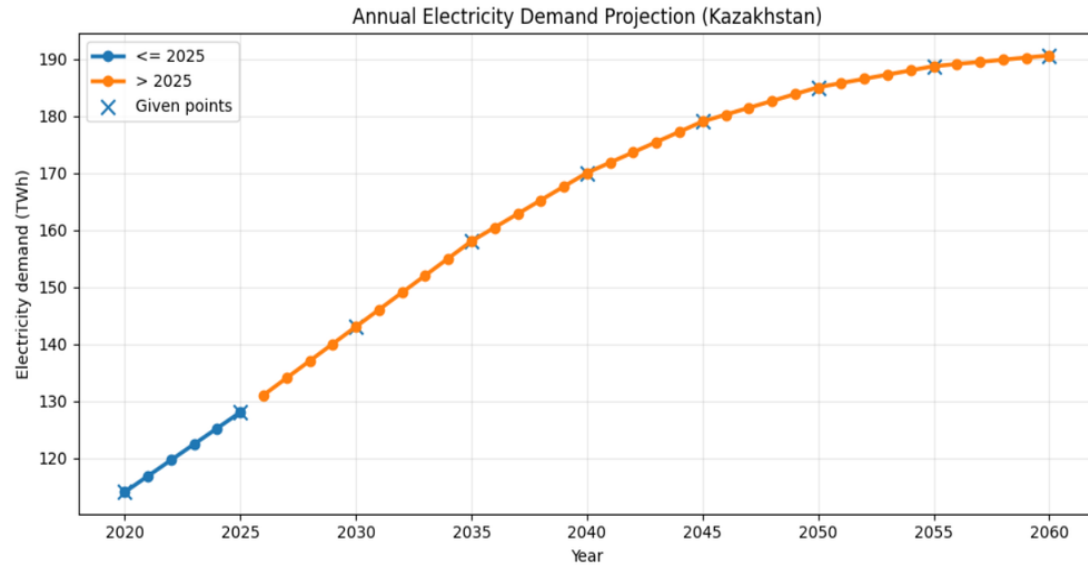

Input#1: Load Projection - separate case

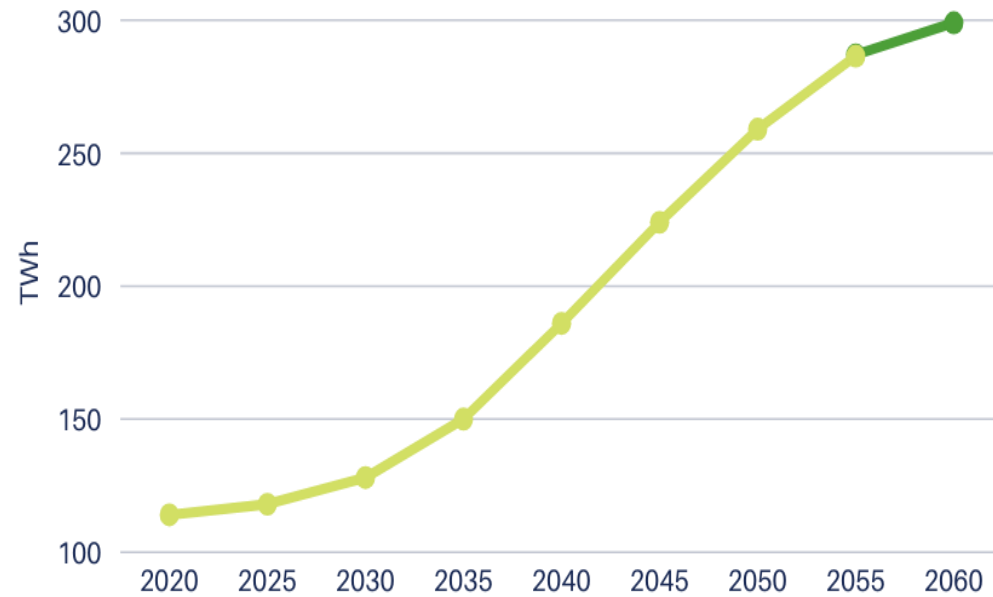

299.8 TWh

in 2060

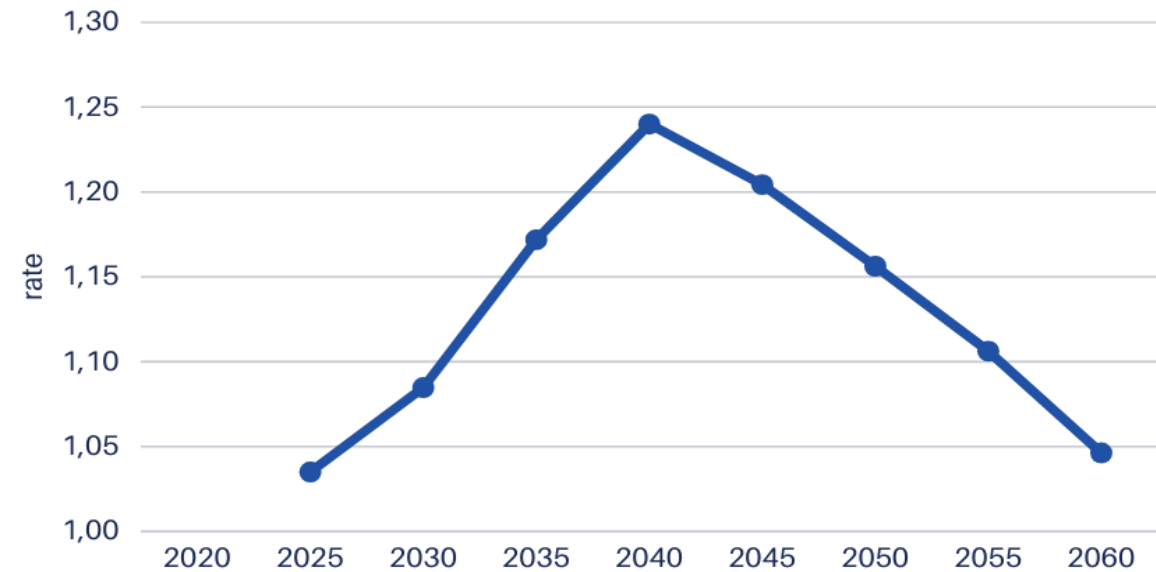

Annual energy data projection (5 year step) is taken, which corresponds to the scenario with highest CO2 cost

Annual Electricity Demand Projection (Kazakhstan)

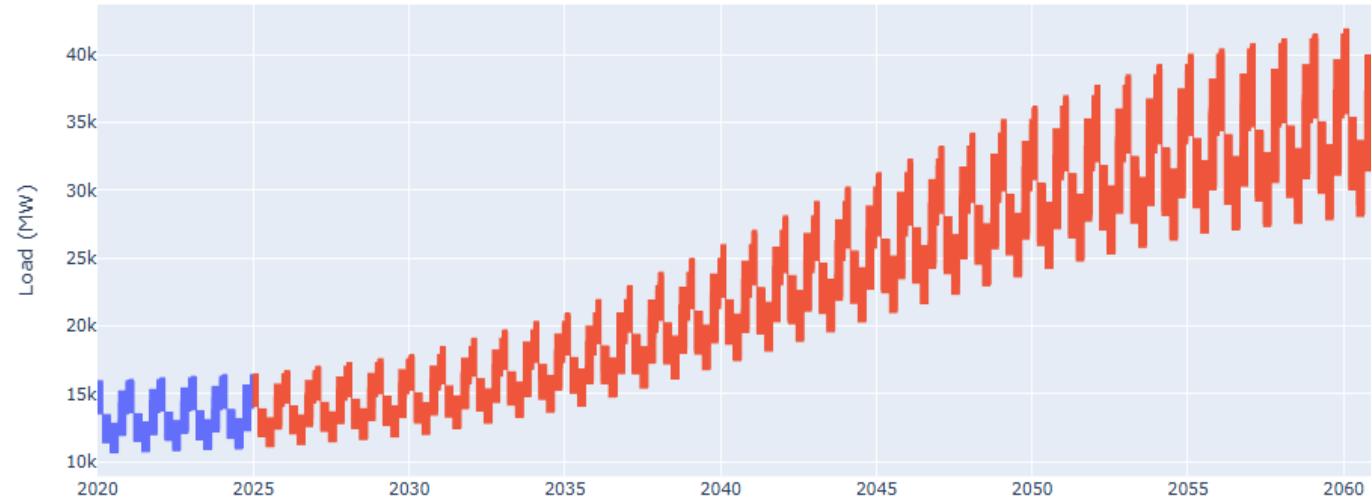
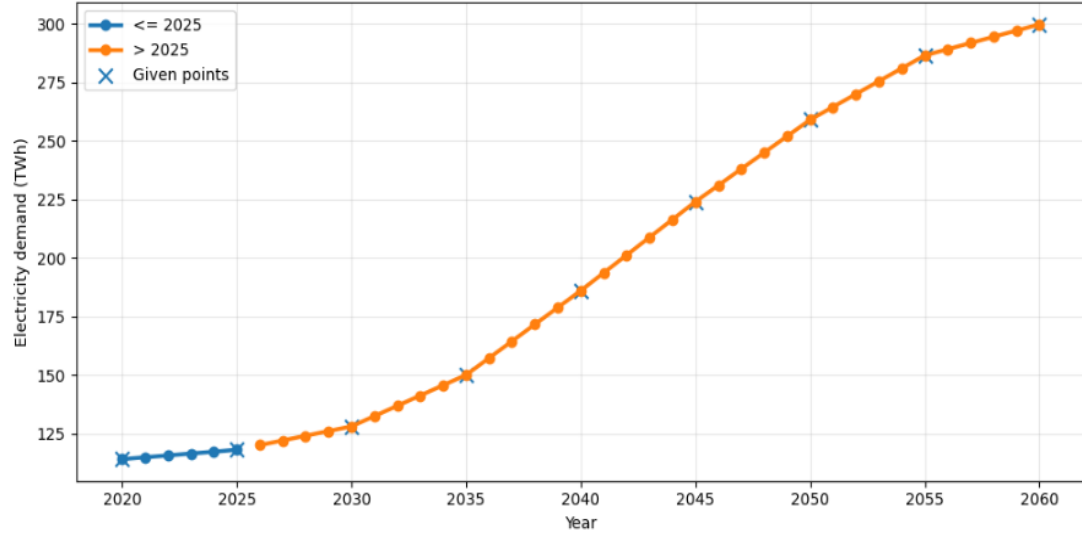

Average daily (diurnal) load profile — 2020 historical vs 2030-2060 forecast

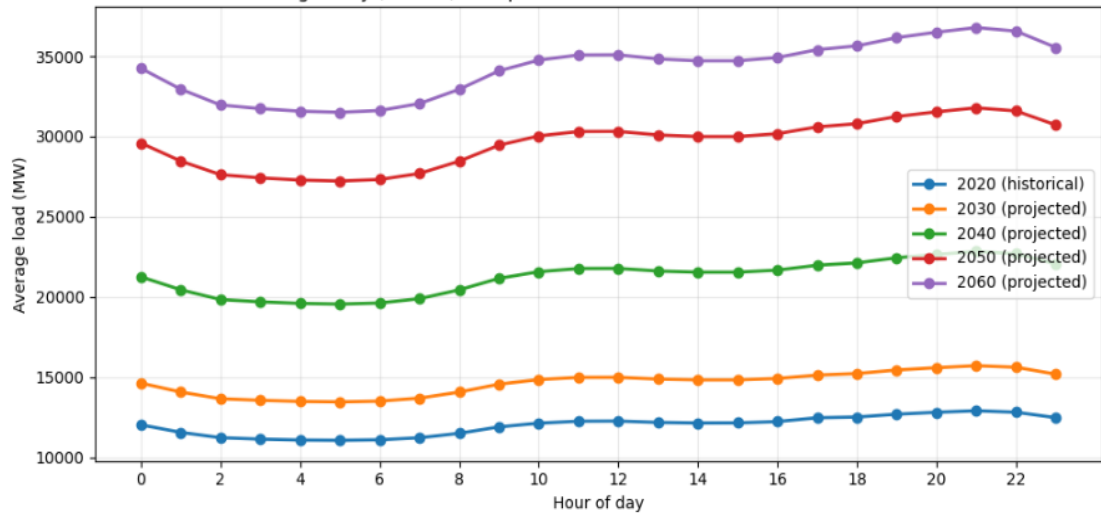

Monthly average load (MW)

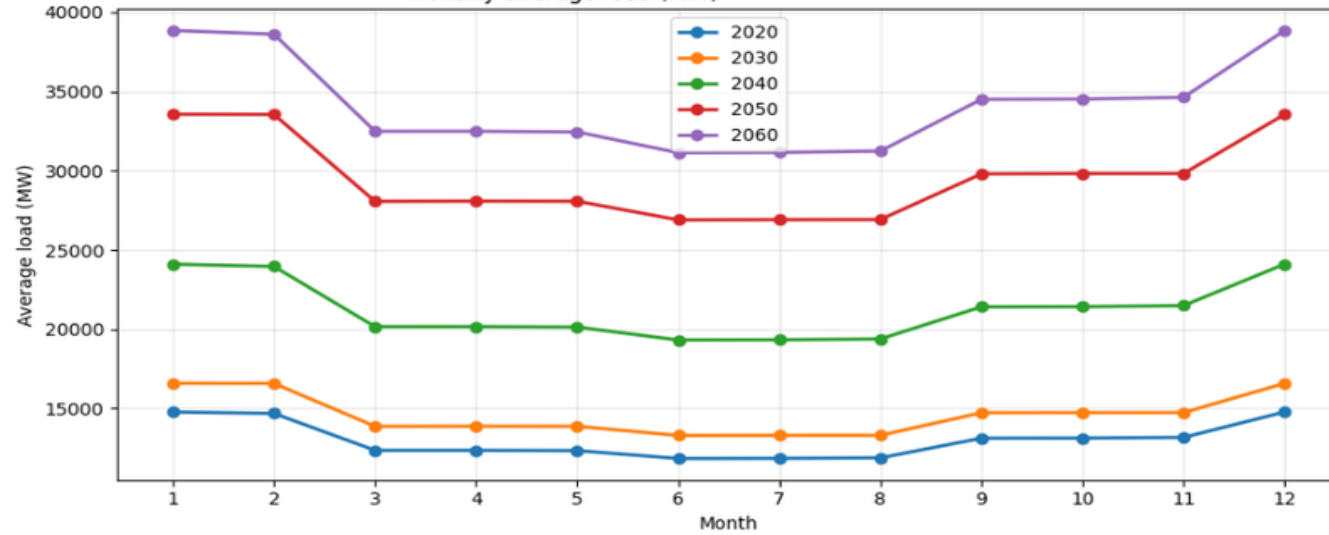

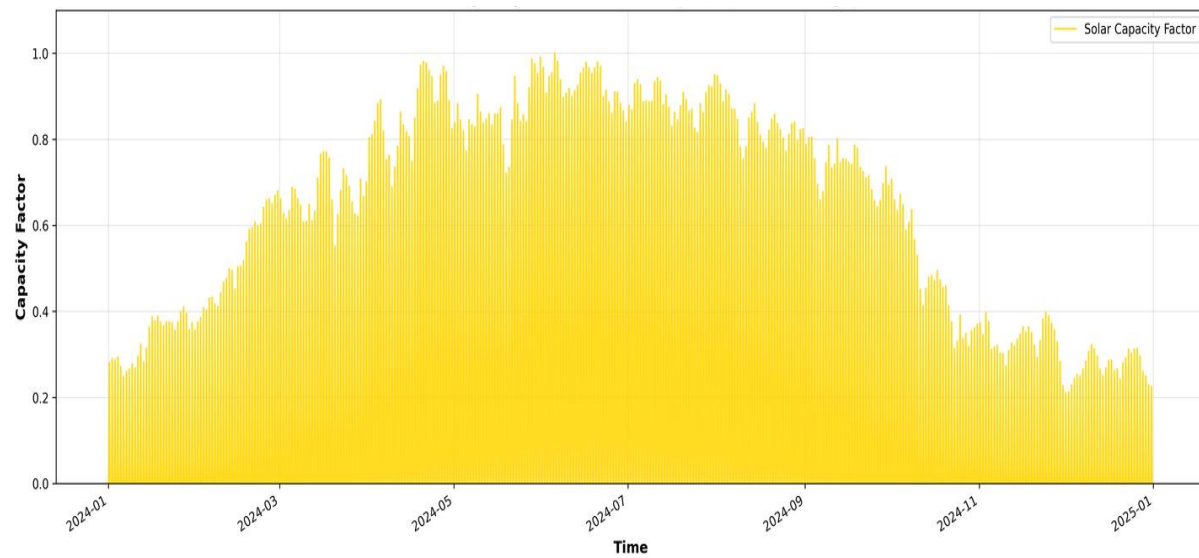
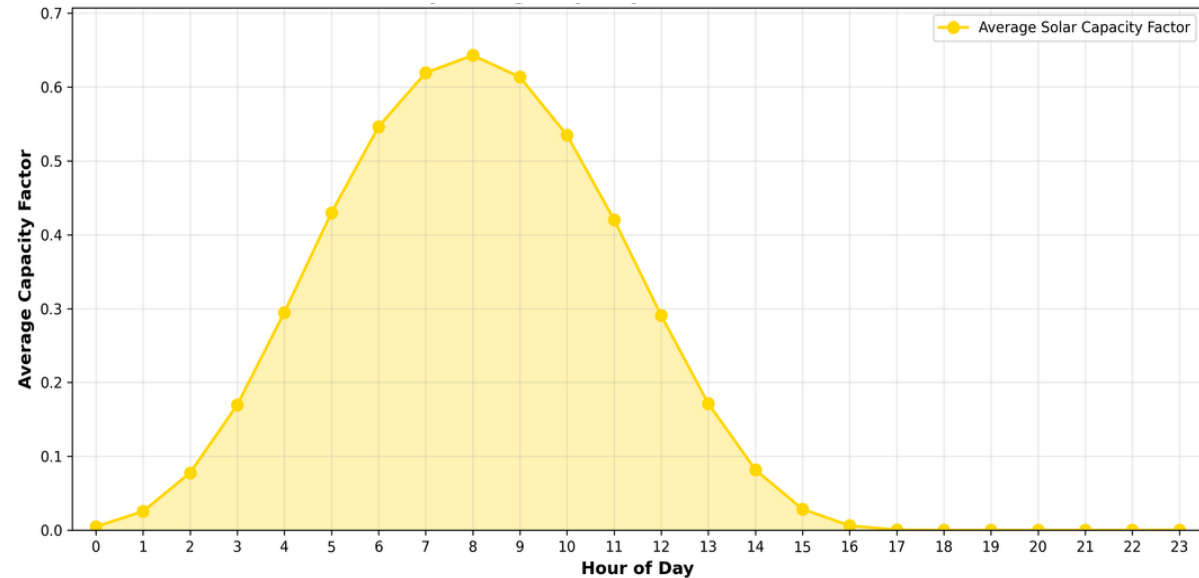

GRIB files for wind and solar information were taken from 'Copernicus' database

Solar related info:

- surface_solar_radiation_downwards
- surface_thermal_radiation_downwards
- surface_net_solar_radiation
- 2m temperature
- surface pressure

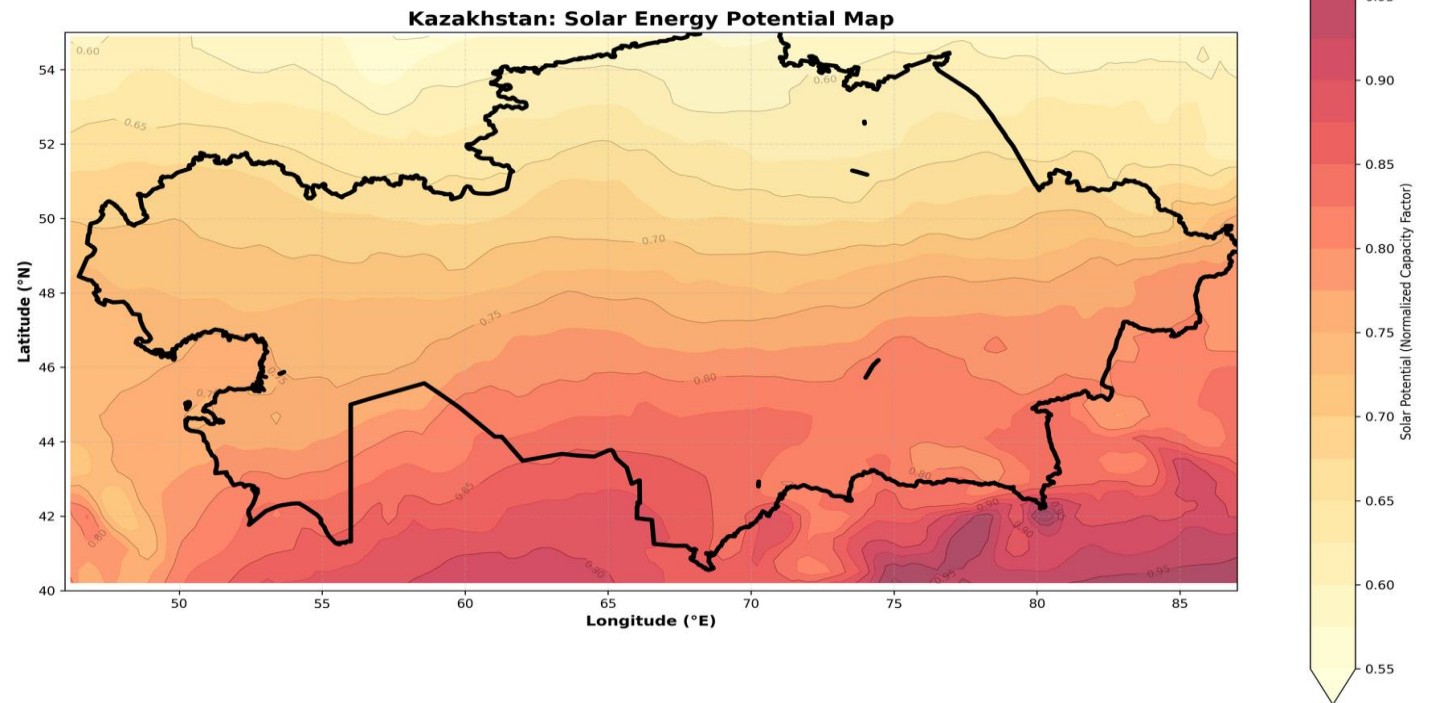

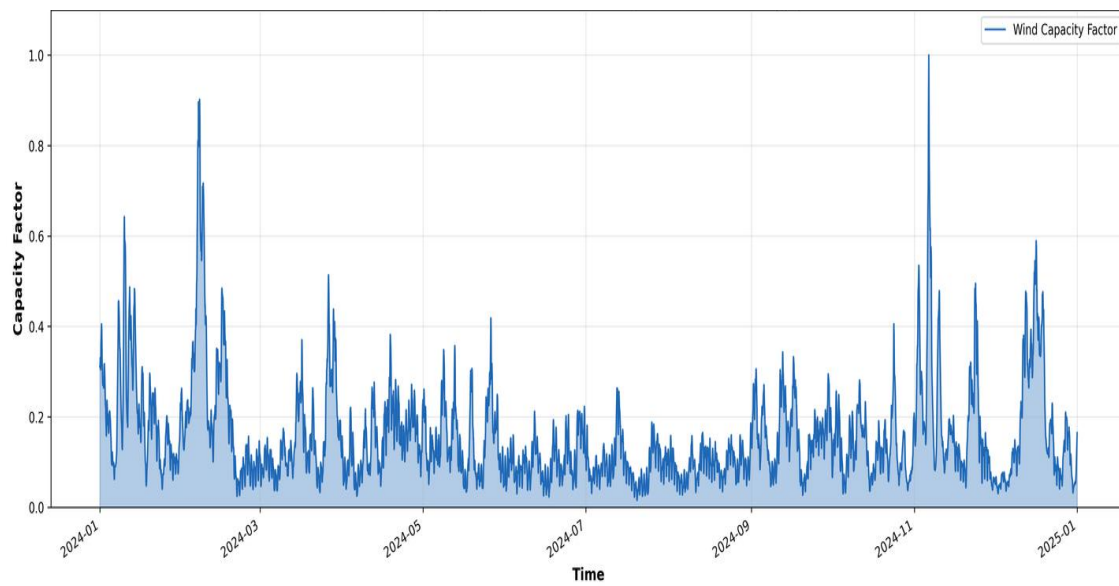
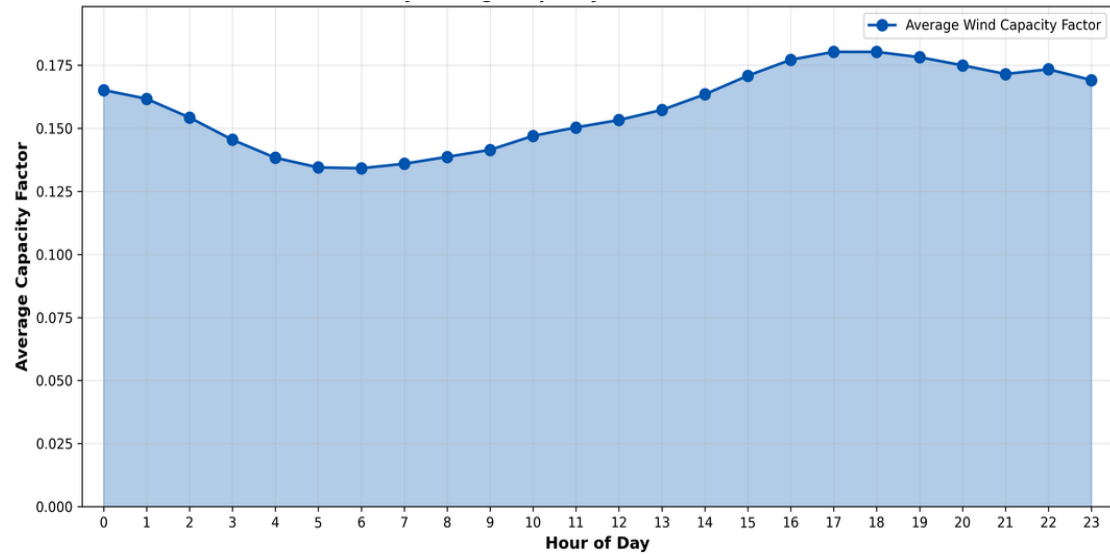

GRIB files for wind and solar information were taken from ‘Copernicus’ database

Wind related info:

- 10m_u_component_of_wind
- 10m_v_component_of_wind
- 100m_u_component_of_wind
- 100m_v_component_of_wind

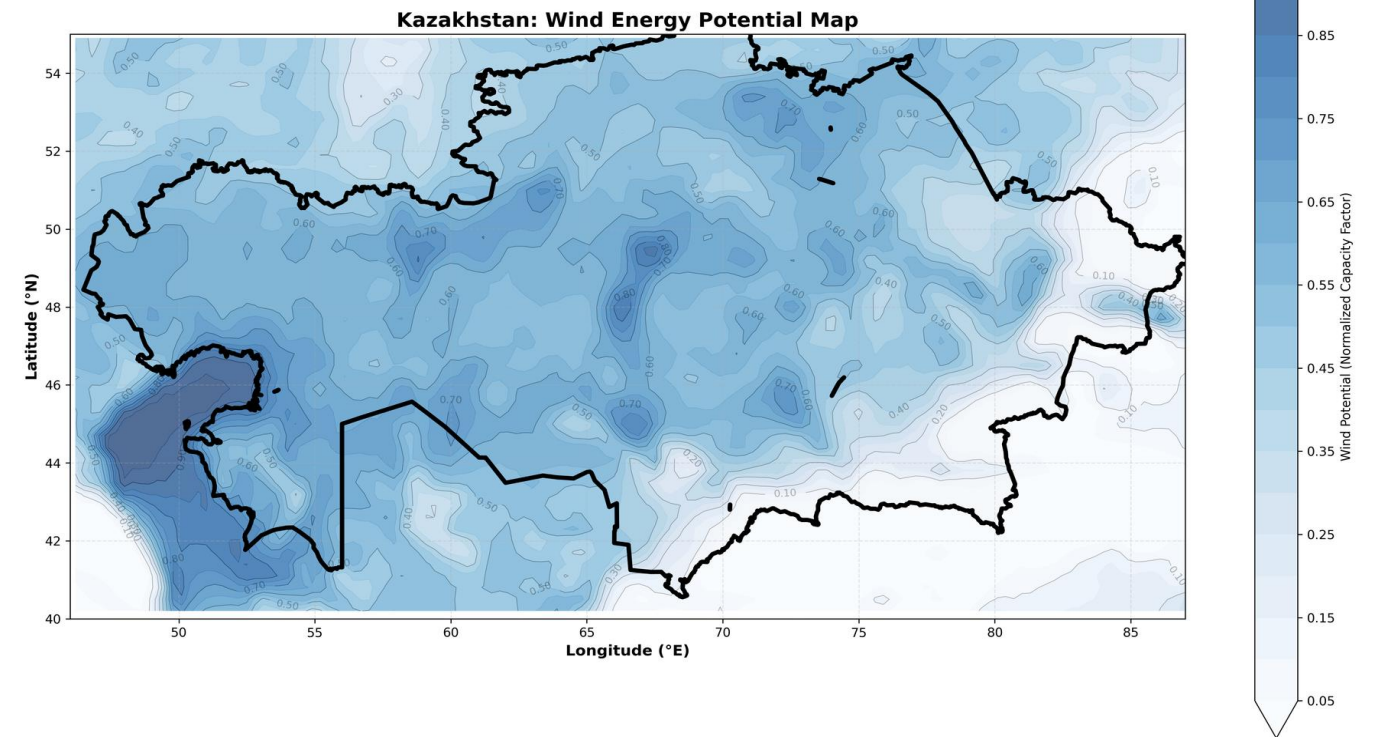

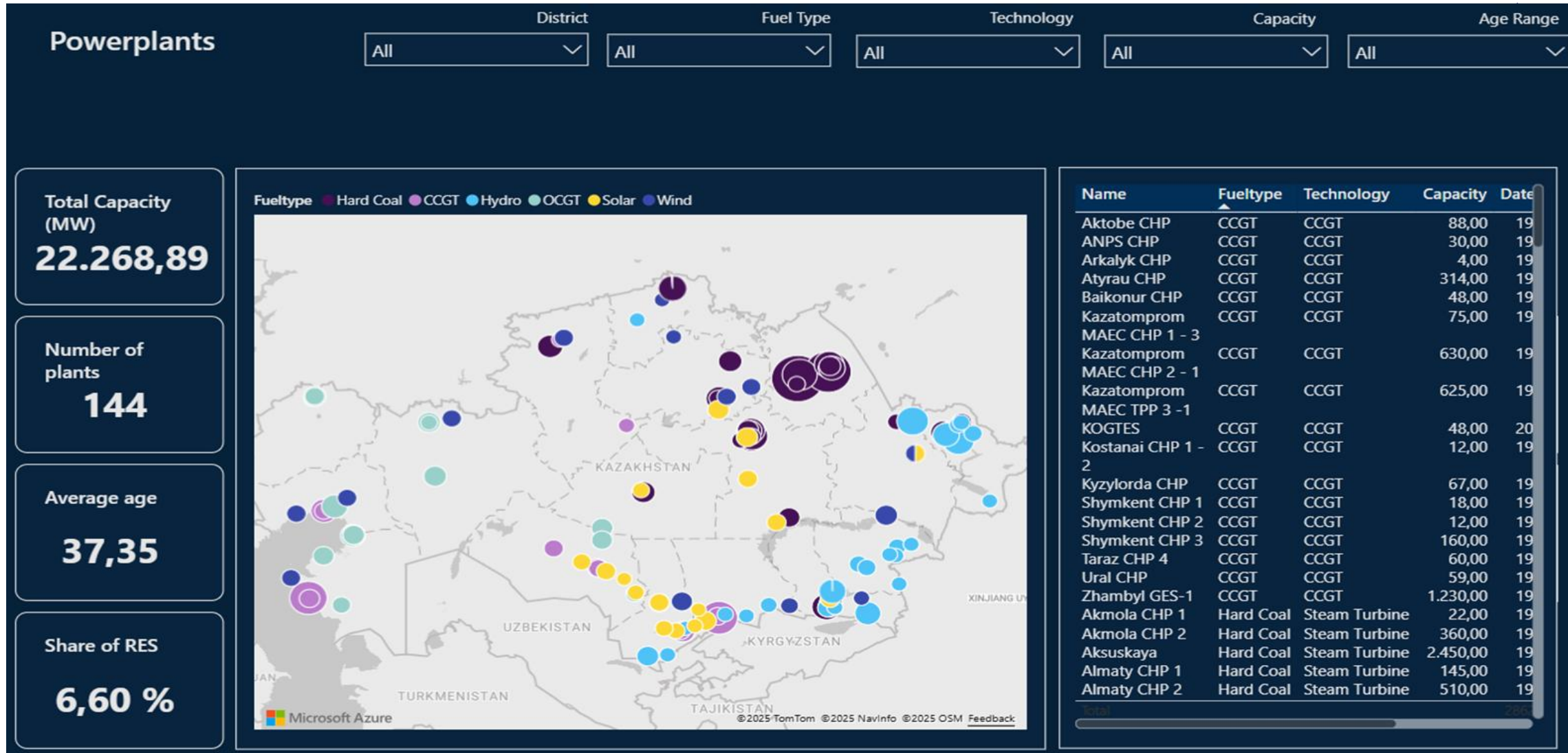

Kazakhstan Electricity Network - Buses and Lines

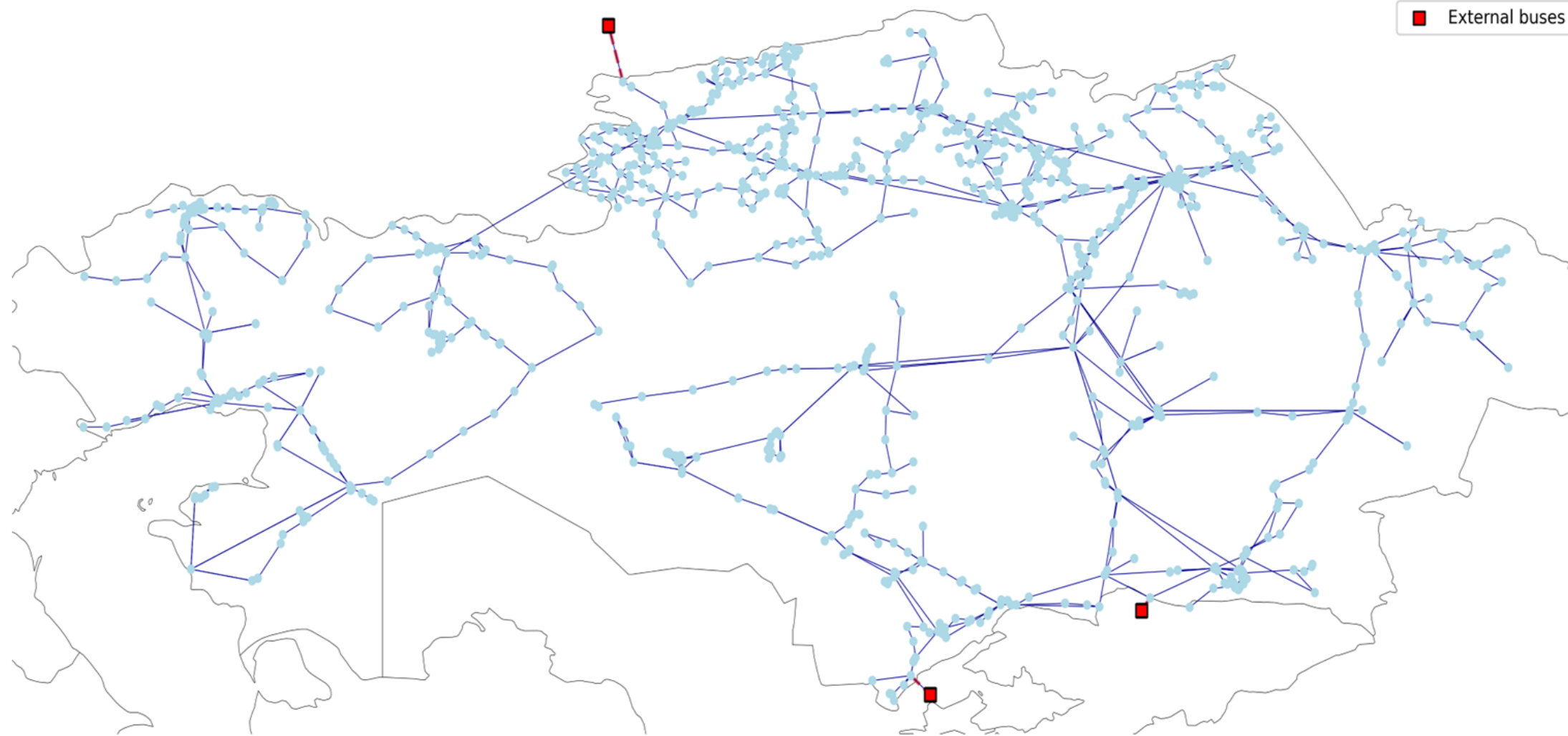

System-Level Outputs: Network Topology

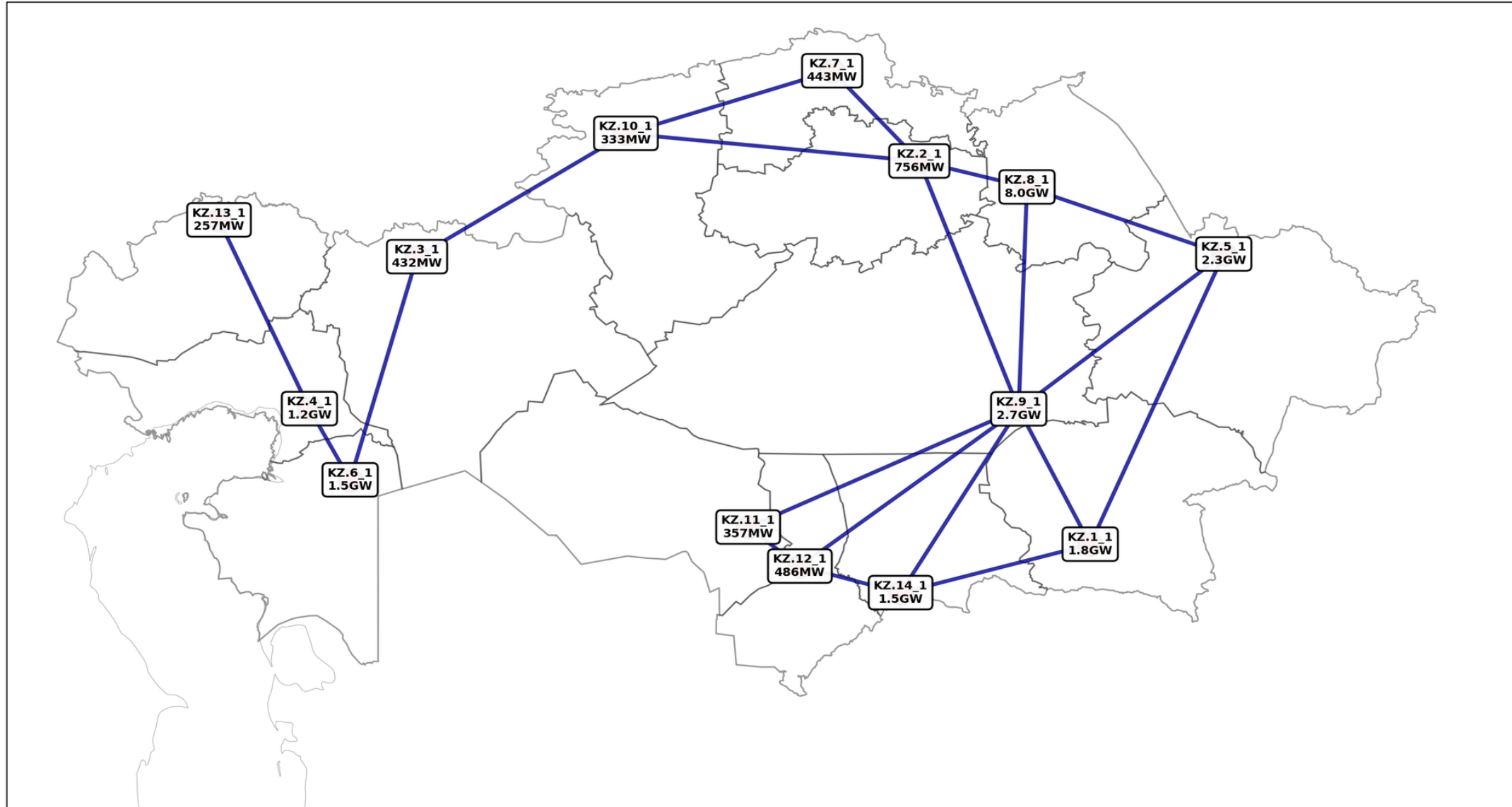

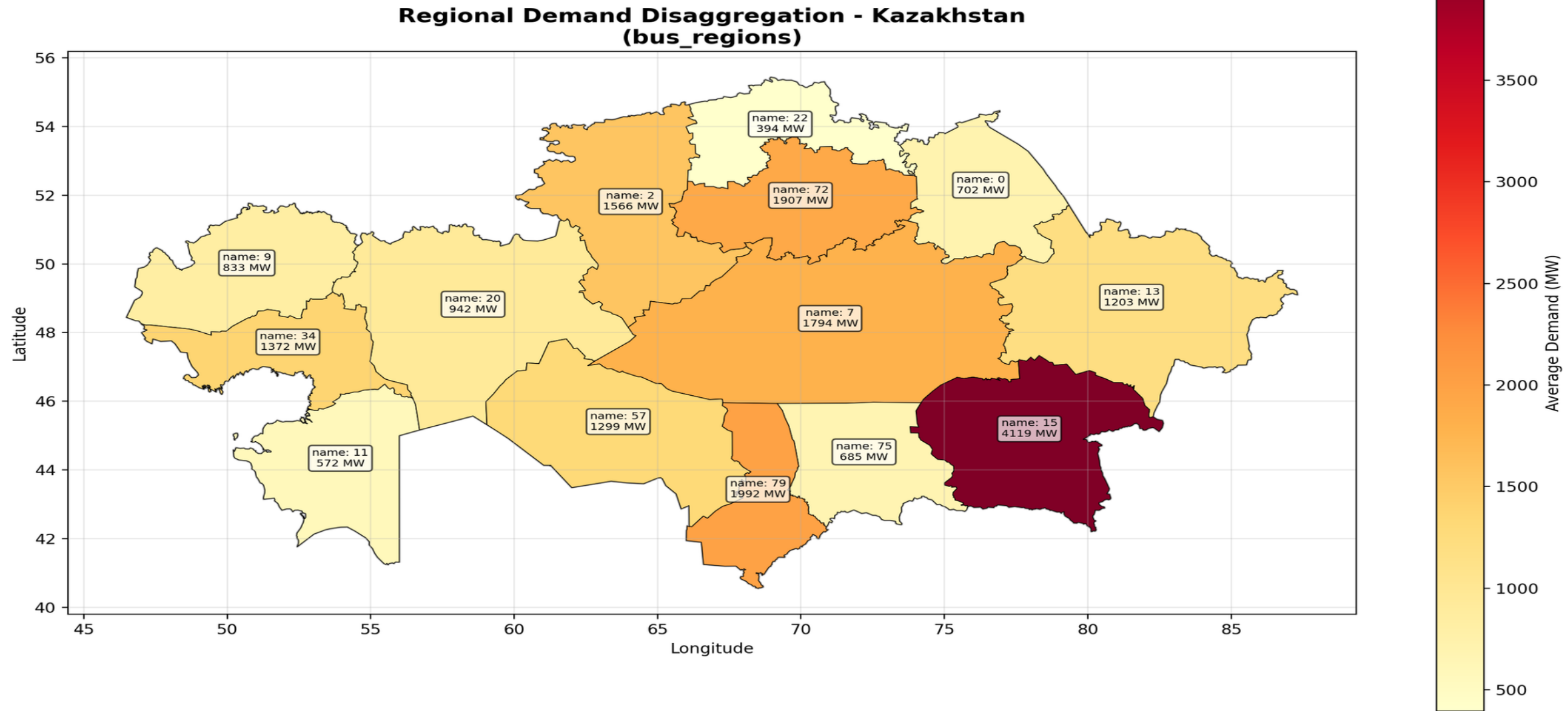

BAU - BUSINESS AS USUAL

Continuation of current trajectory with no new major policy interventions; serves as the reference case for costs, emissions, and risks.

RENEWABLE TARGET

Short-/medium-term stress test: checks if 2030 RES objectives can be achieved with acceptable costs or stability issues.

NUCLEAR INTRODUCTION

Evaluates nuclear as firm low-carbon baseload after 2035 and its system effect

NET ZERO EMISSION BY 2060

Explores a credible pathway consistent with carbon neutrality by 2060, requiring large-scale RES, flexibility, and potentially grid reinforcement under a CO₂ constraint.

What Questions this study aims to answer

*HORIZON: 2026-2060

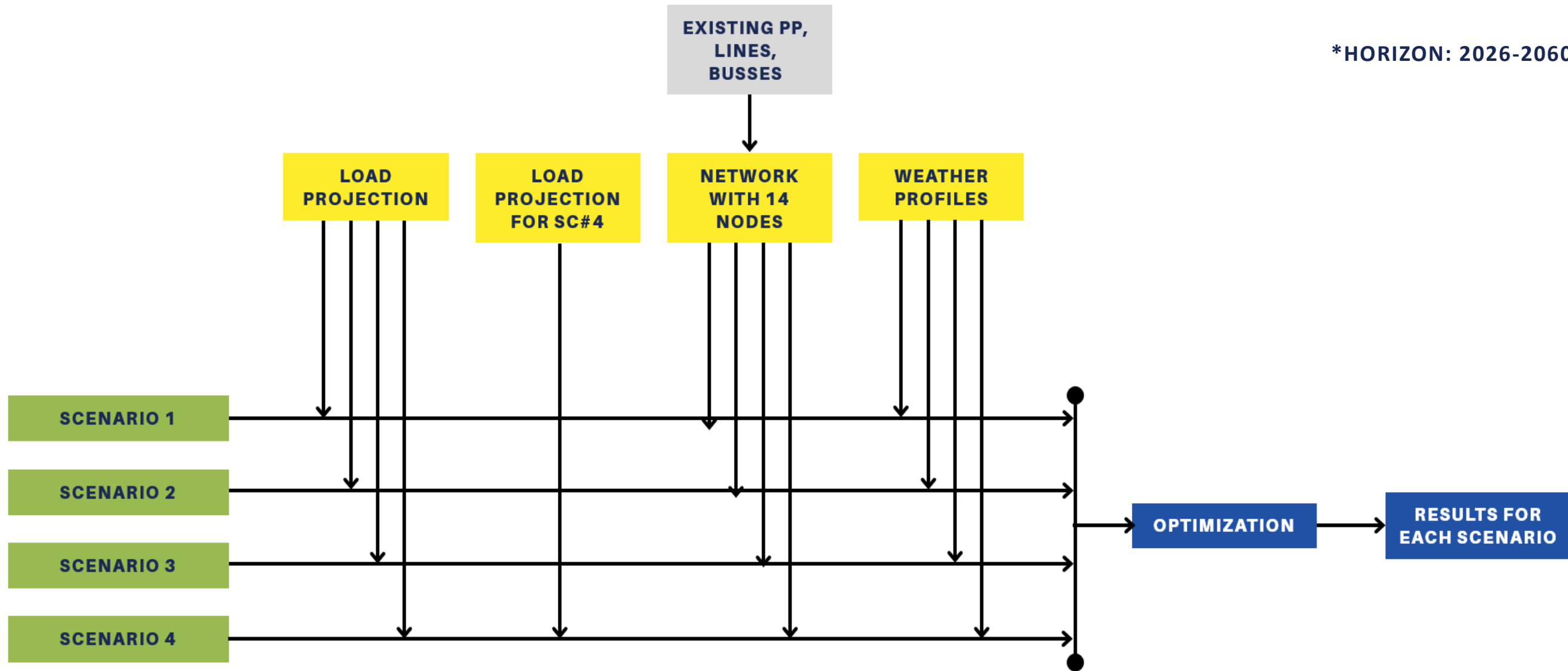

```

INFO:gurobipy:Model fingerprint: 0x73660e36
Coefficient statistics:
INFO:gurobipy:Coefficient statistics:
  Matrix range      [1e-02, 1e+00]
INFO:gurobipy:  Matrix range      [1e-02, 1e+00]
  Objective range   [3e-04, 2e+05]
INFO:gurobipy:  Objective range   [3e-04, 2e+05]
  Bounds range     [1e+01, 8e+08]
INFO:gurobipy:  Bounds range     [1e+01, 8e+08]
  RHS range        [4e-01, 3e+08]
INFO:gurobipy:  RHS range        [4e-01, 3e+08]
Presolve removed 25176246 rows and 1 columns (presolve time = 8s)...
INFO:gurobipy:Presolve removed 25176246 rows and 1 columns (presolve time = 8s)...
Presolve removed 25185878 rows and 4327201 columns (presolve time = 18s)...
INFO:gurobipy:Presolve removed 25185878 rows and 4327201 columns (presolve time = 18s)...
Presolve removed 25185878 rows and 4327201 columns (presolve time = 21s)...
INFO:gurobipy:Presolve removed 25185878 rows and 4327201 columns (presolve time = 21s)...
Presolve removed 25185878 rows and 4327201 columns (presolve time = 25s)...
INFO:gurobipy:Presolve removed 25185878 rows and 4327201 columns (presolve time = 25s)...
Presolve removed 25185878 rows and 4327201 columns (presolve time = 33s)...
INFO:gurobipy:Presolve removed 25185878 rows and 4327201 columns (presolve time = 33s)...
Presolve removed 25185878 rows and 4327201 columns (presolve time = 39s)...
INFO:gurobipy:Presolve removed 25185878 rows and 4327201 columns (presolve time = 39s)...
Presolve removed 25185878 rows and 4327201 columns (presolve time = 40s)...
INFO:gurobipy:Presolve removed 25185878 rows and 4327201 columns (presolve time = 40s)...
Presolve removed 25185878 rows and 4327201 columns
INFO:gurobipy:Presolve removed 25185878 rows and 4327201 columns
Out of memory
INFO:gurobipy:Out of memory
Warning: environment still referenced so free is deferred (Continue to use WLS)
INFO:gurobipy:Warning: environment still referenced so free is deferred (Continue to use WLS)
ERROR:_helpers:An error happened in module 'C:\\Users\\atn\\AppData\\Local\\anaconda3\\envs\\pypsa\\Lib\\site-packages\\gurobipy\\_model.cp311-win_amd64.pyd', function 'gurobipy._model.Model.optimize': Out of memory
Traceback (most recent call last):
  File "C:\\Users\\atn\\pypsa-earth\\.snakemake\\shadow\\tmp5jtlwngl\\.snakemake\\scripts\\tmpss5855bu.solve_ne

```

assumption

2026–2060 = 35 years = 306,816 hourly snapshots

investment decisions mostly depend on typical system behaviour, not on every single hour of every year.

Operational-year sampling

We solve only a few carefully selected “representative years”, but we weight them so that their energy, costs, and emissions represent the full 35-year period exactly.

Instead of solving all 35 years, we solve only: [2026, 2030, 2035, 2040, 2045, 2050, 2055, 2060]

For example:

2026 represents 4 years.

In total = 35064 hours.

Operational year hours = 8760

Weight = $35064/8760 \approx 4.0027$

So every hour in 2026 is counted 4.0027 times in:

- Energy totals
- Costs
- Emissions
- CO₂ constraints
- RES shares

Operational year	Represents
2026	2026–2029
2030	2030–2034
2035	2035–2039
2040	2040–2044
2045	2045–2049
2050	2050–2054
2055	2055–2059
2060	2060

Inputs & Key Assumption

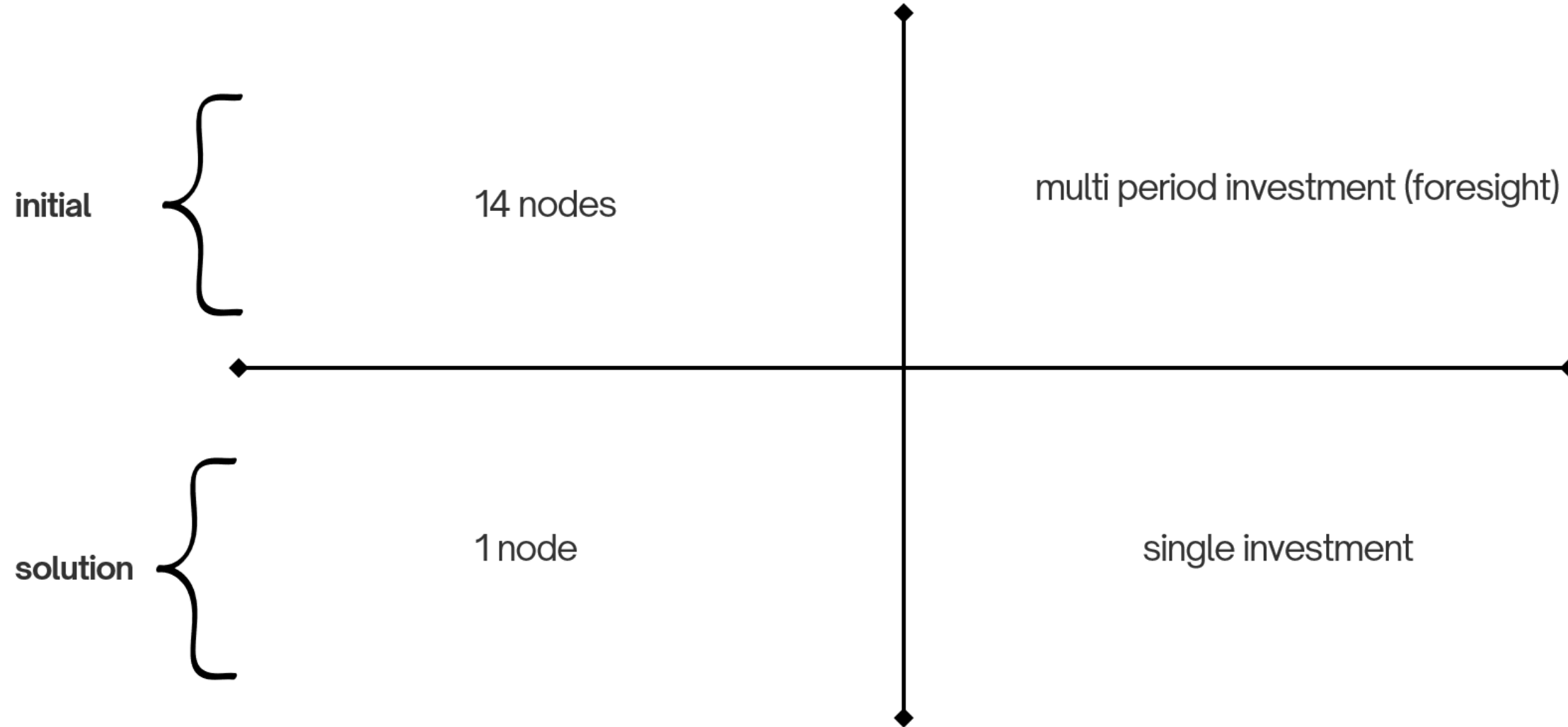

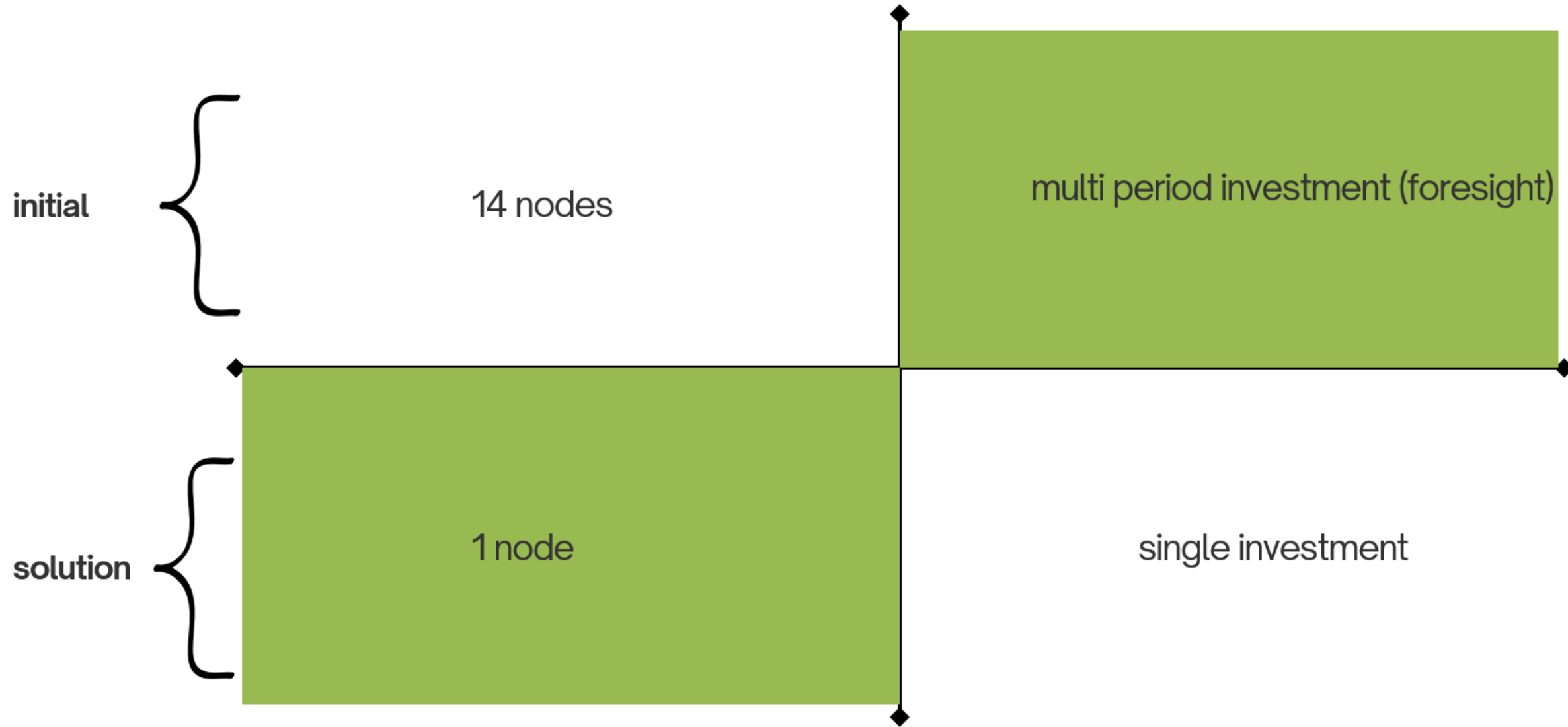

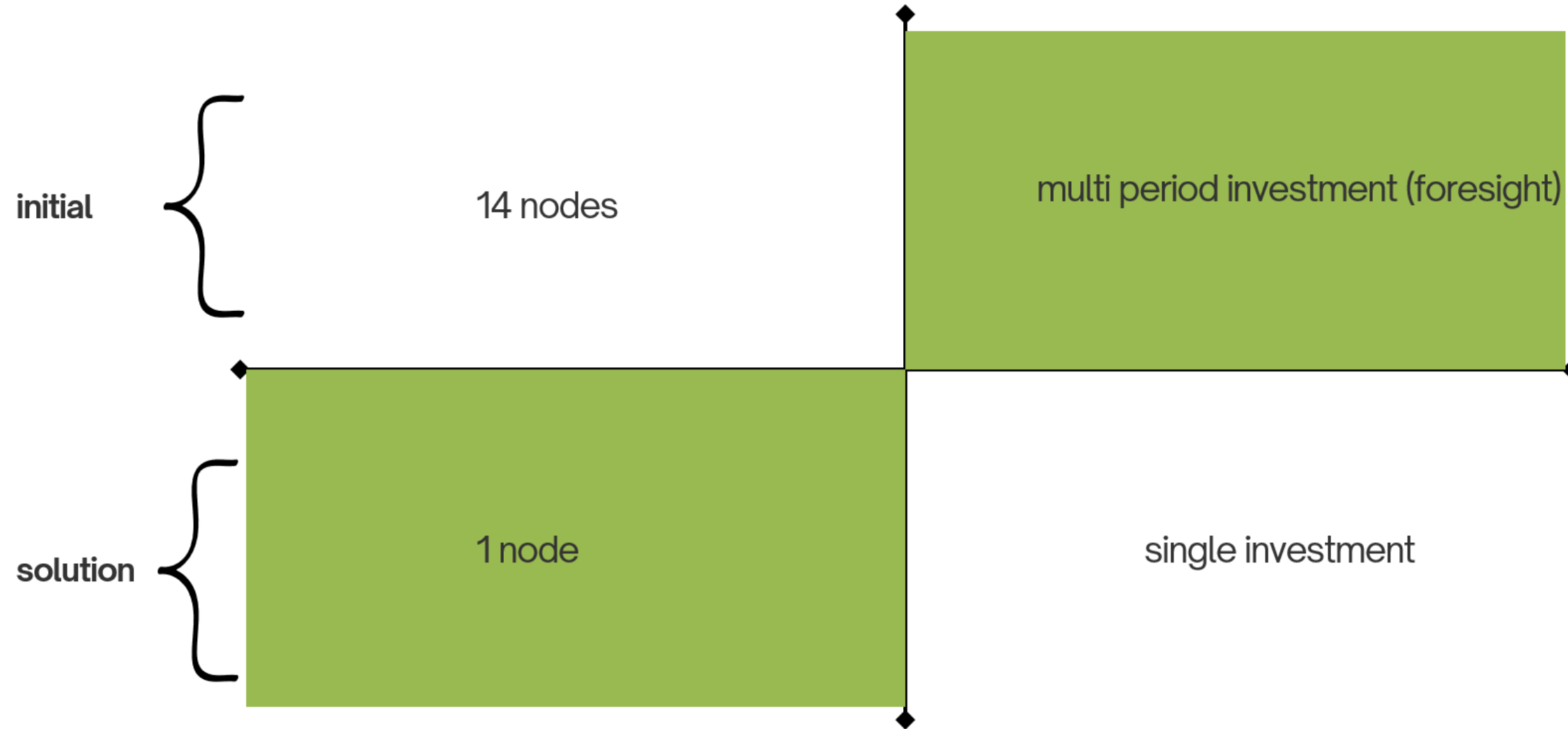

*but we are going to lose inter-regional analysis and the answer for the question: where the new plants are going to be built?

```
! environmentyaml X
envs > ! environmentyaml
1 # SPDX-FileCopyrightText: PyPSA-Earth and PyPSA-Eur Authors
2 #
3 # SPDX-License-Identifier: AGPL-3.0-or-later
4
5 name: pypsa-earth
6 channels:
7 - conda-forge
8 - bioconda
9 - gurobi
10 dependencies:
11 - python>=3.10, <3.12 # 3.12 has weird issues with snakemake https://github.com/snakemake/snakemake/issues/2480
12 - pip
13
14 - pypsa>=0.25.1, <=0.30.3
15 - atlite>=0.4.1
16 - dask
17 - powerplantmatching>=0.8
18 - earth-osm>=2.3.post1
19
20 # Dependencies of the workflow itself
21 - xlrd
22 - openpyxl
23 - seaborn
24 - snakemake-minimal<8
25 - memory_profiler
26 - ruamel.yaml<=0.17.26
27 - pytables
28 - pycipopt
29 - lxml
30 - numpy<2
31 - pandas
32 - geopandas>=1
33 - fiona>=1.10
34 - xarray>=2023.11.0, <=2025.01.2
35 - netcdf4
36 - libgdal-netcdf
```

```
environmentyaml X
envs > ! environmentyaml
35 - netcdf4
36 - libgdal-netcdf
37 - networkx
38 - scipy<1.16
39 - pydoe2
40 - shapely!=2.0.4
41 - pre-commit
42 - matplotlib
43 - reverse-geocode
44 - country_converter
45 - pyogrio
46 - numba
47 - py7zr
48 - tsam>=1.1.0
49 - fake-useragent
50 - chaospy
51 - geopy
52 - tqdm
53 - pytz
54
55 # Cloud download
56 # - googledrivedownloader # Commented until https://github.com/conda-forge/googledrivedownloader-feedstock/pull/7 is merged
57
58 # Jupyter notebook requirement
59 - ipykernel
60 - ipython
61 - jupyterlab
62
63 # GIS dependencies:
64 - cartopy
65 - rasterio
66 - rioxarray
67
68 # Plotting
69 - geoviews
70 - hvplot
71 - graphviz
72 - contextily
73
74 # Default solver for tests (required for CI)
75 - glpk
76 - gurobi
77
78 # Command Line Interface
```

Final setup → RAM situation

```

2 3.24416583e+09 -5.72192550e+09 9.04e+02 4.55e-13 4.50e+03 6s
3 1.51172616e+09 -2.84707744e+08 7.83e+01 5.68e-13 6.66e+02 7s
4 7.99520412e+08 5.57658498e+08 4.42e+00 7.39e-13 8.04e+01 7s
5 7.47350939e+08 6.23105845e+08 1.53e+00 3.98e-13 4.07e+01 8s
6 7.23733557e+08 6.79870327e+08 3.41e-01 2.27e-13 1.43e+01 8s
7 7.17448112e+08 6.84736273e+08 2.03e-01 1.99e-13 1.06e+01 9s
8 7.12799138e+08 6.98392221e+08 1.01e-01 1.78e-13 4.68e+00 9s
9 7.10239087e+08 7.03831127e+08 5.23e-02 1.86e-13 2.08e+00 10s
10 7.08601470e+08 7.05262203e+08 2.37e-02 1.62e-13 1.08e+00 10s
11 7.07924652e+08 7.06377550e+08 1.27e-02 1.85e-13 5.02e-01 11s
12 7.07448963e+08 7.06771978e+08 5.39e-03 1.75e-13 2.20e-01 11s
13 7.07220807e+08 7.06952659e+08 2.02e-03 1.71e-13 8.71e-02 12s
14 7.07161009e+08 7.07018024e+08 1.19e-03 1.68e-13 4.64e-02 12s
15 7.07100535e+08 7.07038676e+08 3.72e-04 1.65e-13 2.01e-02 13s
16 7.07094137e+08 7.07046224e+08 2.85e-04 1.50e-13 1.56e-02 13s
17 7.07085735e+08 7.07058102e+08 1.79e-04 1.63e-13 8.97e-03 14s
18 7.07082823e+08 7.07062963e+08 1.42e-04 1.55e-13 6.45e-03 14s
19 7.07078209e+08 7.07065579e+08 8.46e-05 1.59e-13 4.10e-03 15s
20 7.07077839e+08 7.07066226e+08 8.00e-05 1.44e-13 3.77e-03 15s
21 7.07077627e+08 7.07066515e+08 7.74e-05 1.60e-13 3.61e-03 15s
22 7.07076128e+08 7.07067567e+08 5.96e-05 1.51e-13 2.78e-03 16s
23 7.07075940e+08 7.07067786e+08 5.73e-05 1.67e-13 2.65e-03 17s
24 7.07074386e+08 7.07069206e+08 3.89e-05 1.42e-13 1.68e-03 17s

Barrier solved model in 24 iterations and 17.46 seconds (8.45 work units)
Optimal objective 7.07074386e+08

Warning: environment still referenced so free is deferred (Continue to use WLS)
INFO:linopy.constants: Optimization successful:
Status: ok
Termination condition: optimal
Solution: 1576800 primals, 3127320 duals
Objective: 7.07e+08
Solver model: available
Solver message: 2

INFO:pypsa.optimization.optimize:The shadow-prices of the constraints Generator-fix-p-lower, Generator-f
ageUnit-fix-p_dispatch-lower, StorageUnit-fix-p_dispatch-upper, StorageUnit-fix-p_store-lower, StorageUr
e-lower, StorageUnit-fix-state_of_charge-upper, StorageUnit-energy_balance were not assigned to the netw
INFO:__main__:Maximum memory usage: (3854.60546875, 1769709948.3976767)
INFO:pypsa.network.io:Exported network 'Unnamed Network' saved to 'results/kz-bau-myopic-1node/networks/
s, carriers, loads, buses, links, storage_units

```

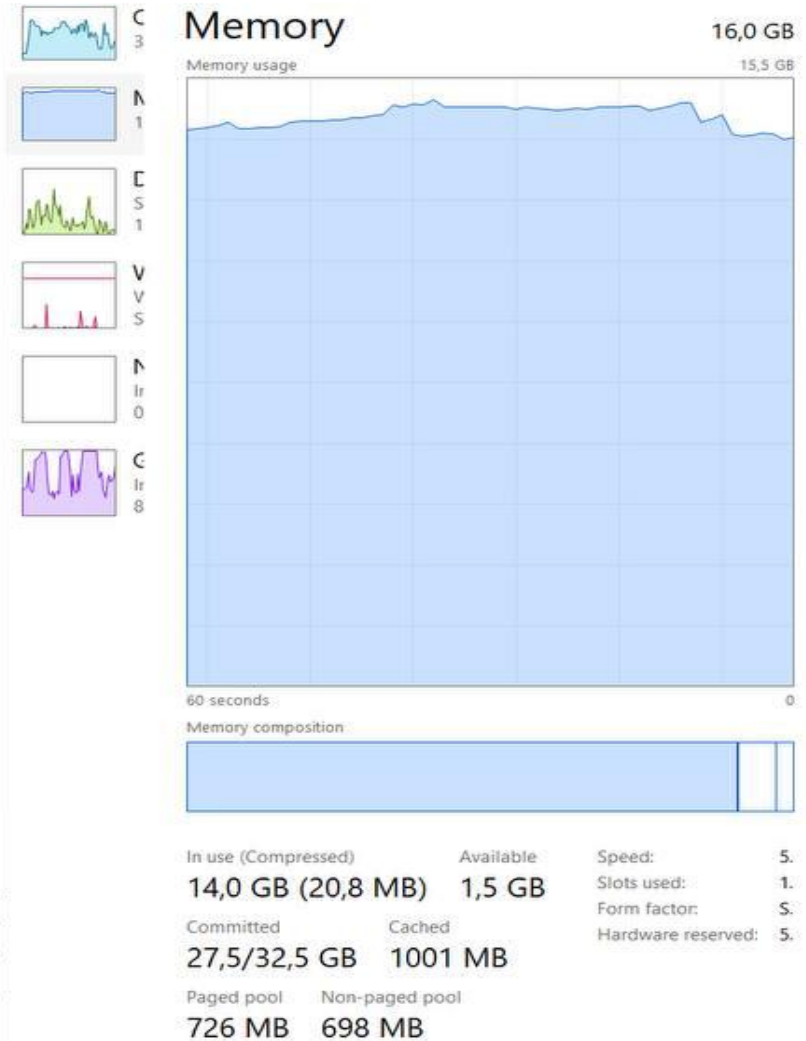

Energy Mix - Annual Generation by Source (2026-2060)

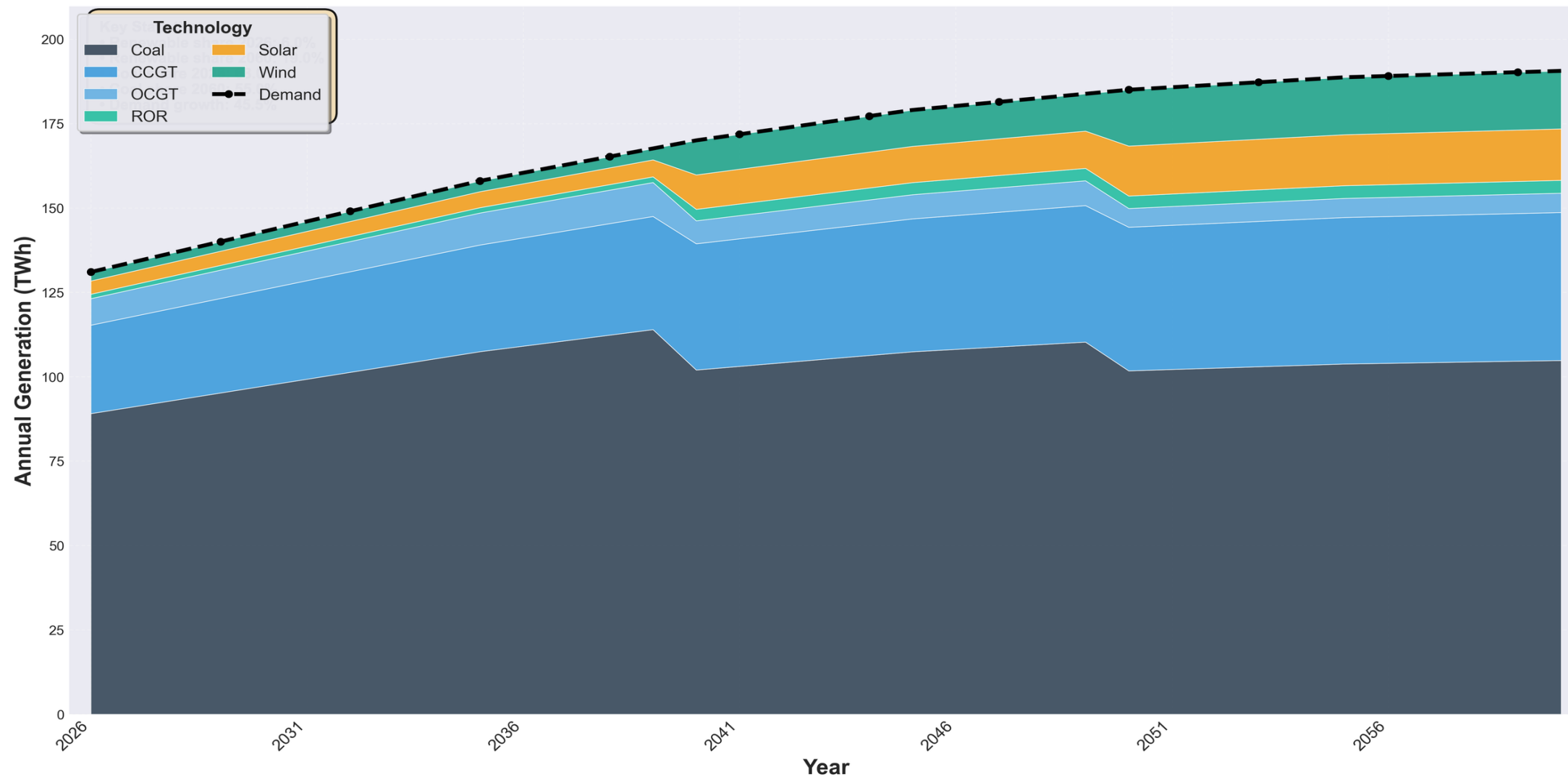

Total Emission	Total cost
4.33 GtCO2	287.69 B€

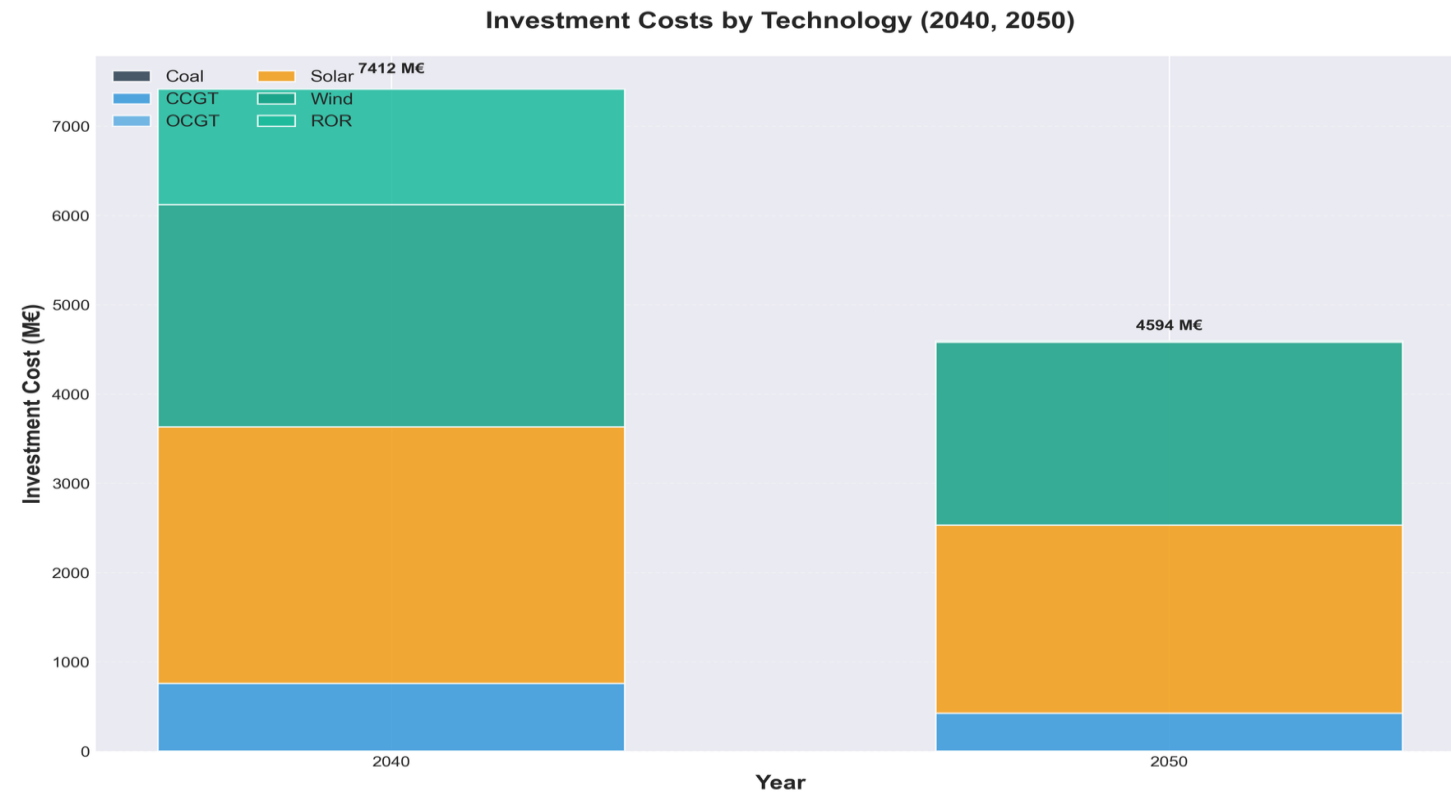

Energy Mix - Annual Generation by Source (2026-2060)

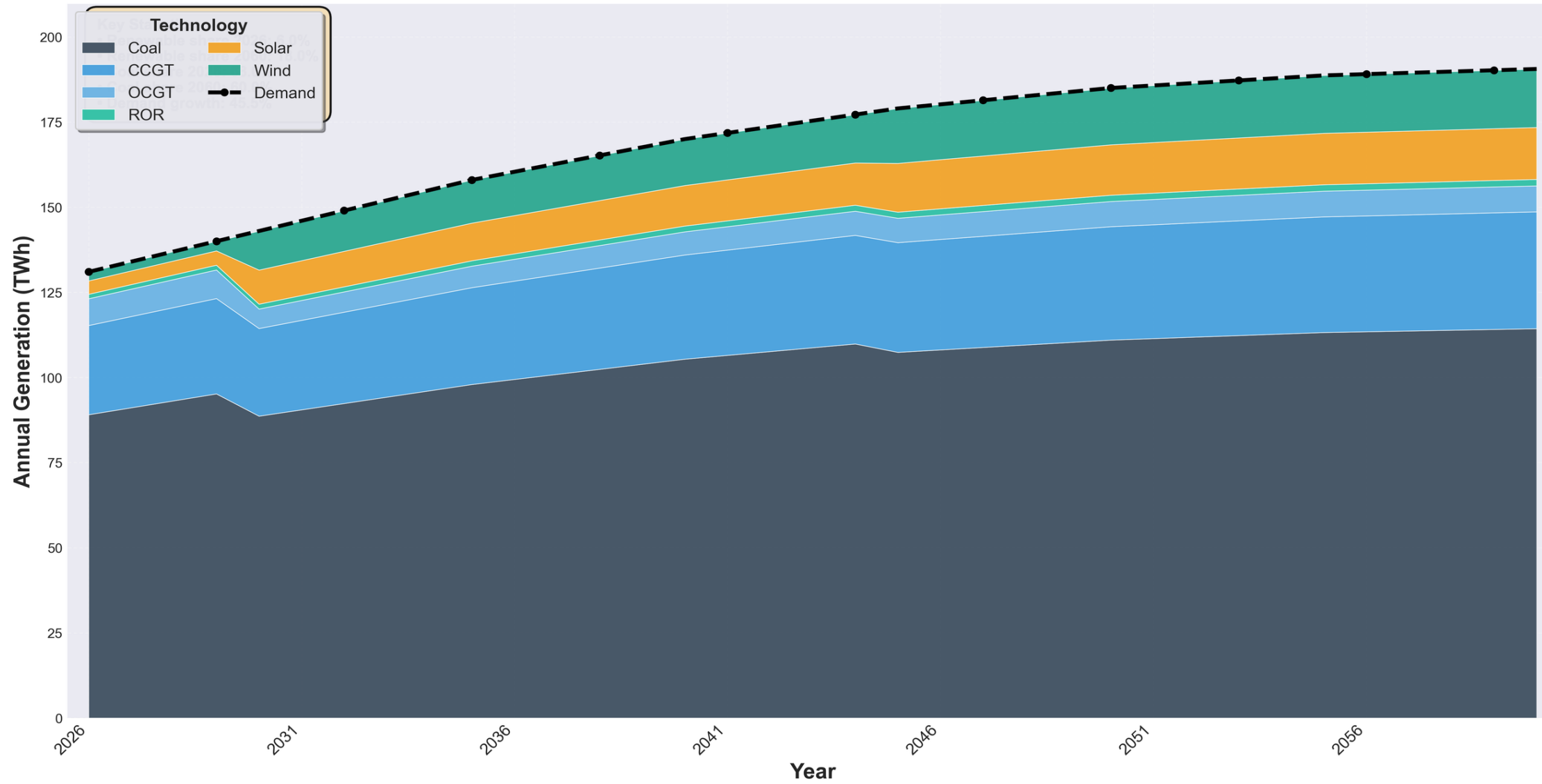

Total Emission	Total cost
4.28 GtCO2	343.79 B€

Investment Costs by Technology (2030, 2045)

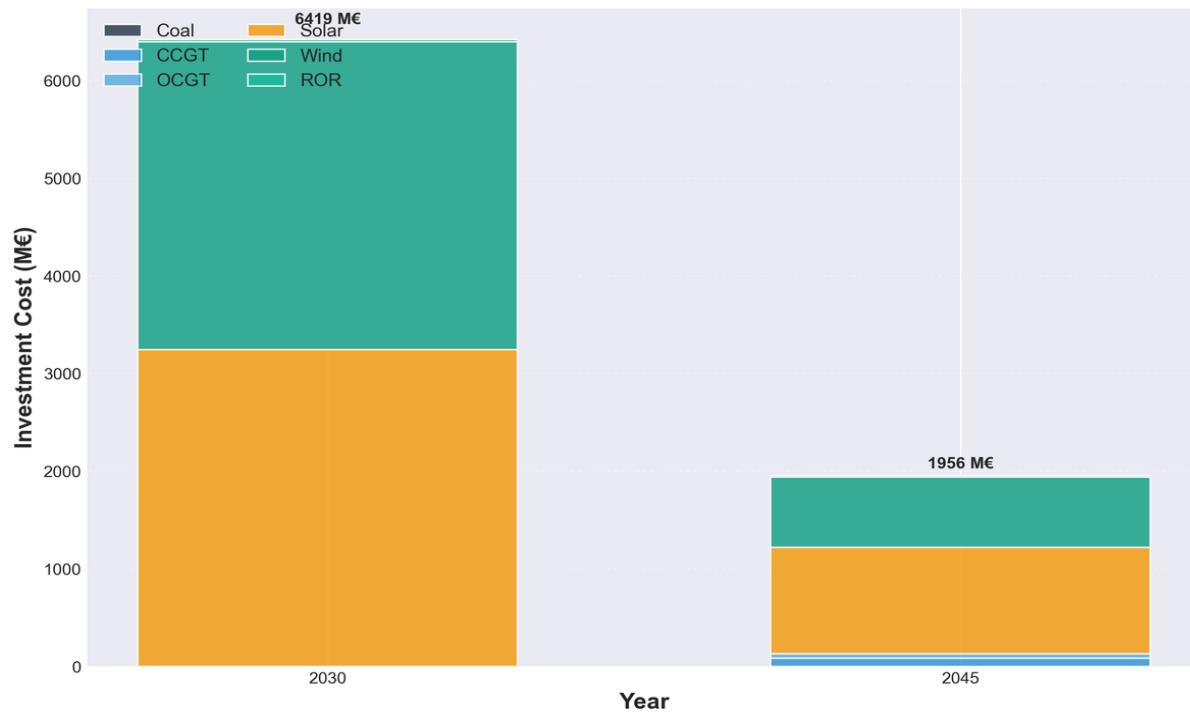

Technology	Generation 2030 (TWh)	Share 2030	Generation 2060 (TWh)	Share 2060
Coal	88.66	62.0%	114.35	60.0%
CCGT	25.74	18.0%	34.31	18.0%
OCGT	5.72	4.0%	7.62	4.0%
Solar	10.01	7.0%	15.25	8.0%
Wind	11.44	8.0%	17.15	9.0%
ROR	1.43	1.0%	1.91	1.0%
Total	143.00	100.0%	190.59	100.0%

Nuclear Scenario - Annual Energy Mix by Source (2026-2060)

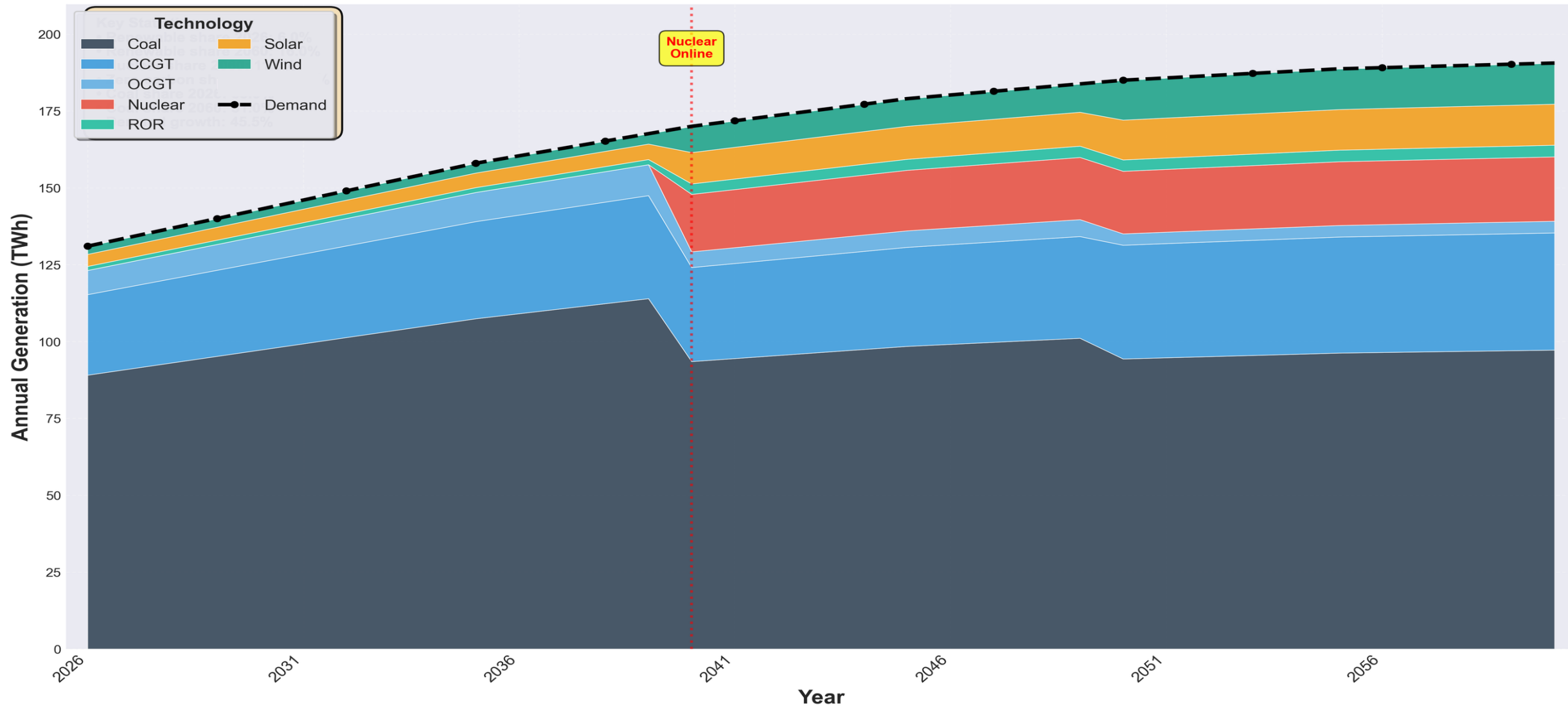

Total Emission	Total cost
4.09 GtCO2	363.49 B€

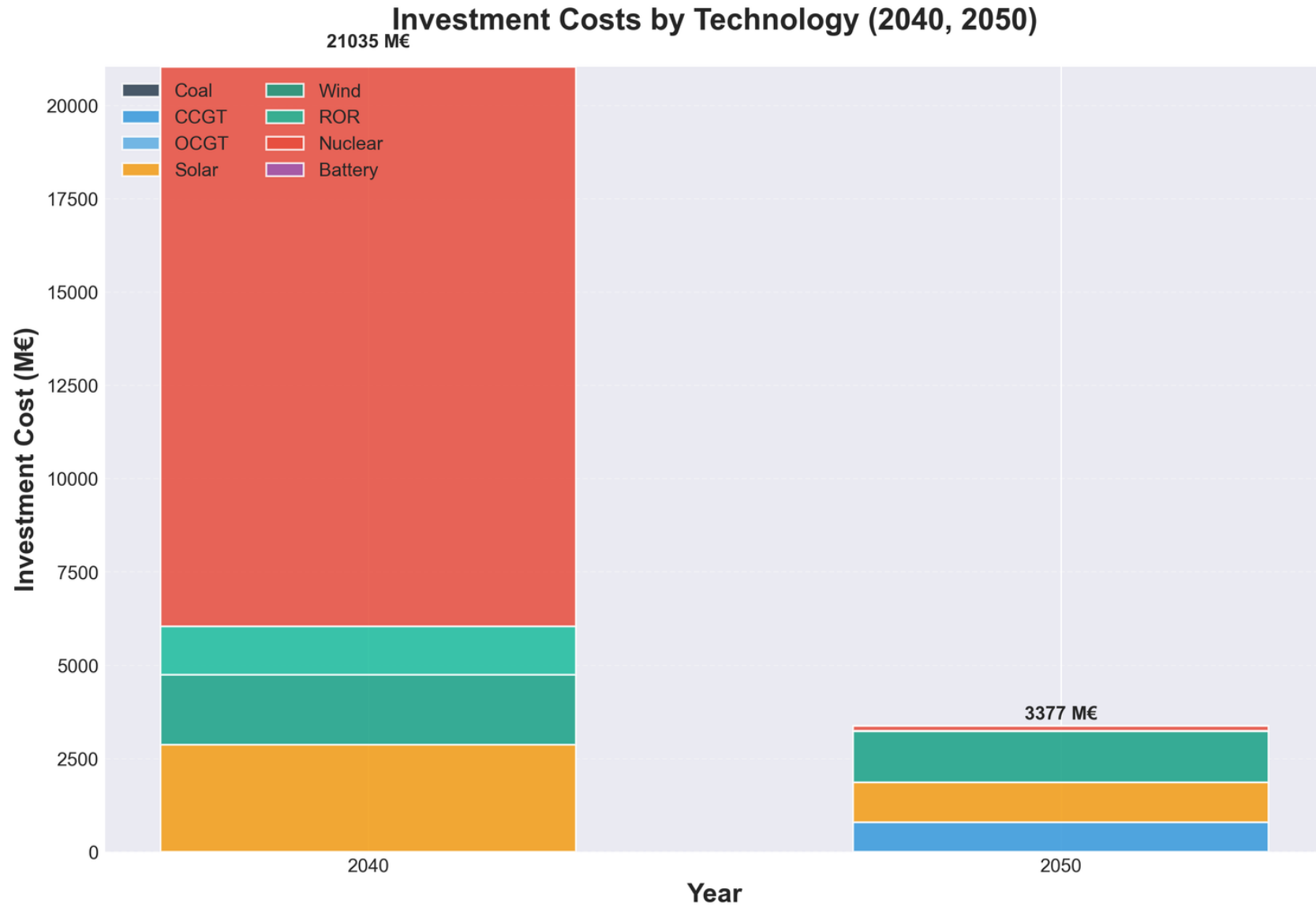

Demand: Baseline

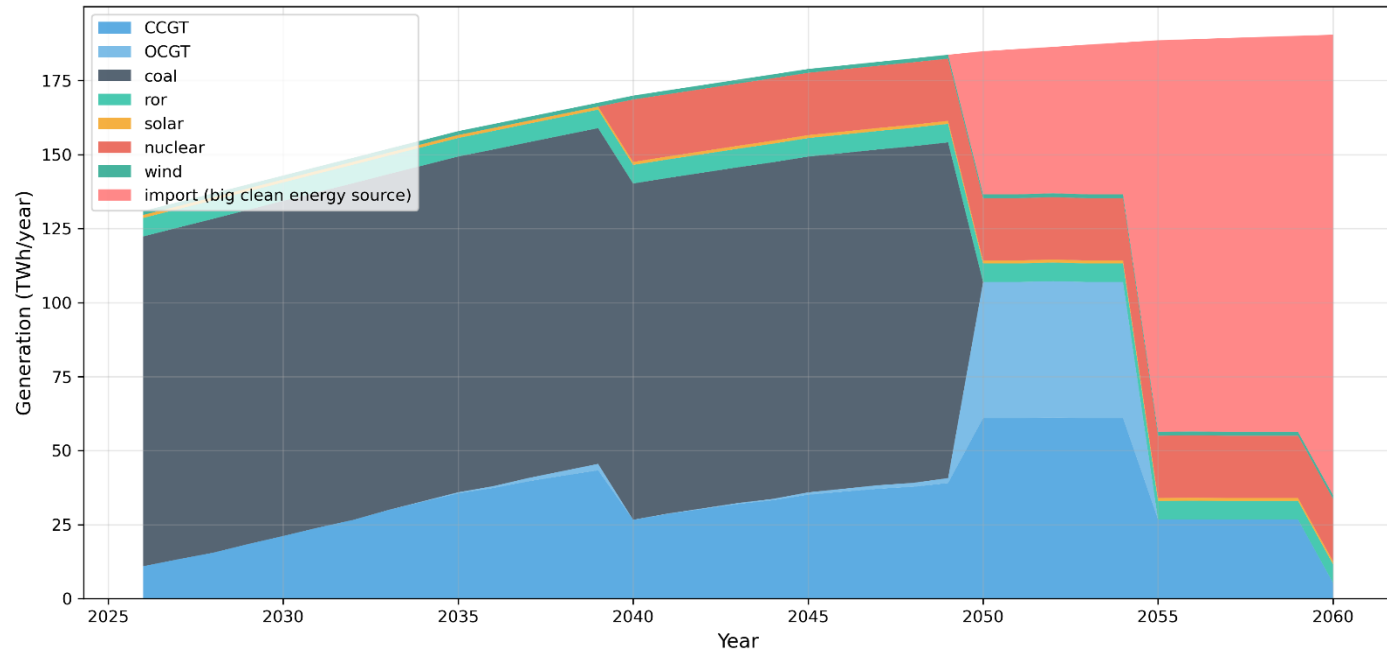

Demand: Net Zero scenario adopted z

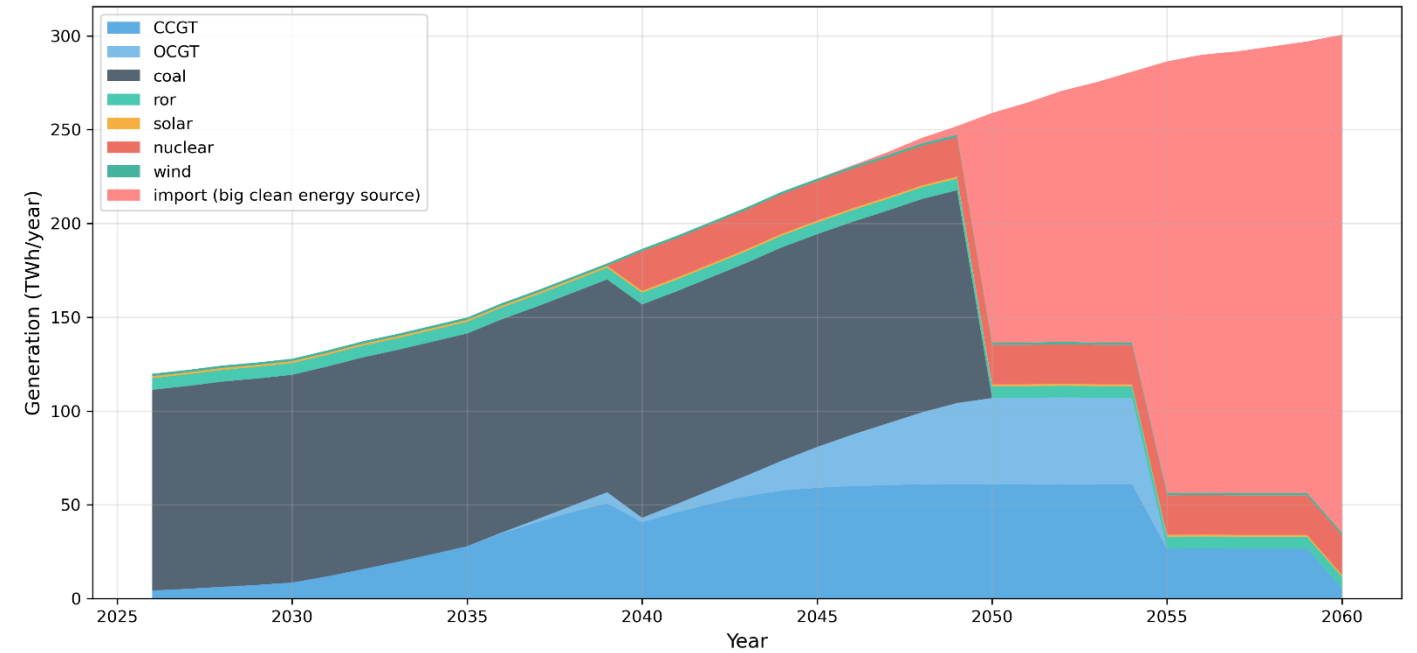

* Virtual imaginary plant with big capacity, high marginal cost and with zero emissions at 500 EUR/MWh cost was introduced to avoid model infusibility

Demand: Baseline

Total Emission	Total cost
1.35 GtCO ₂	534.05 B€

Demand: Net Zero scenario adopted z

Total Emission	Total cost
1.38 GtCO ₂	1539 B€

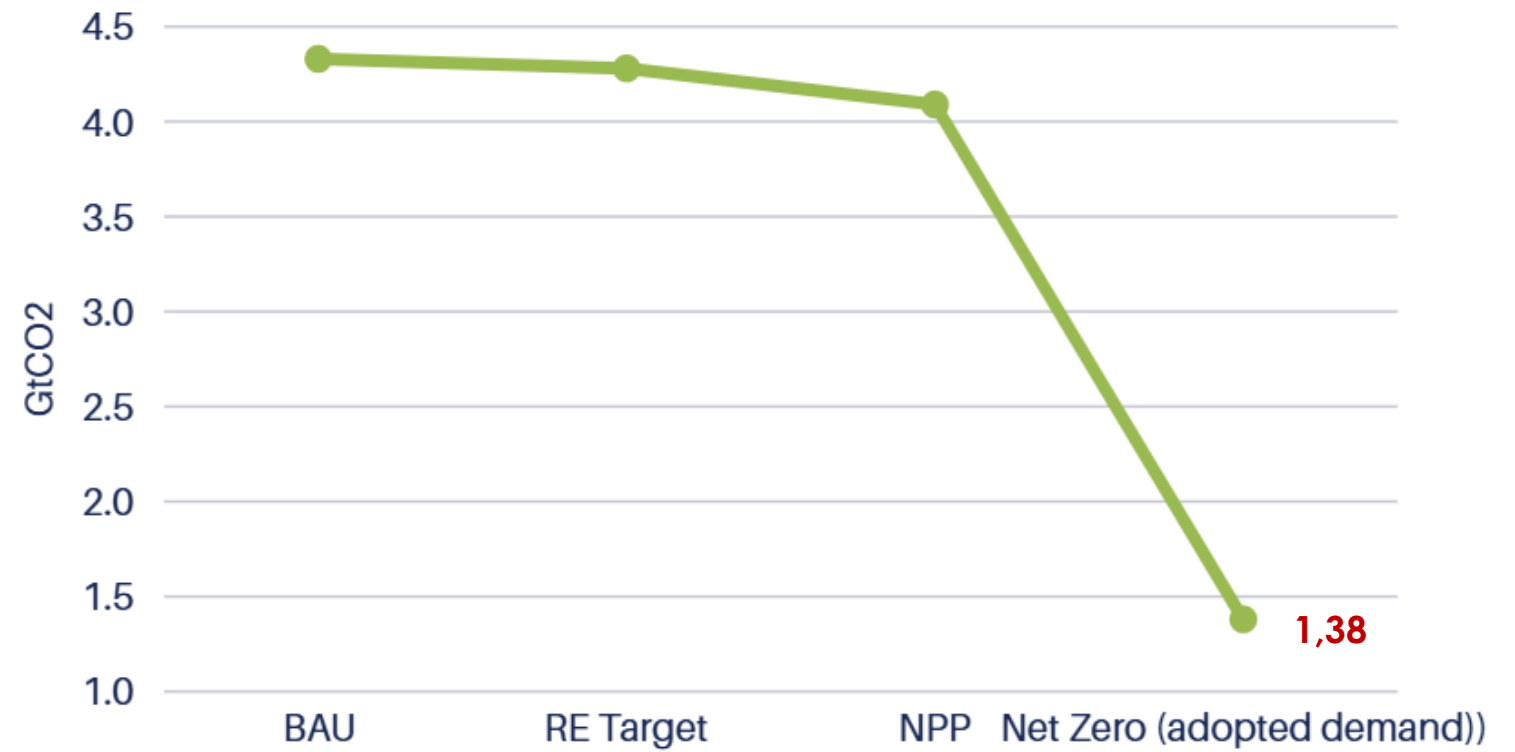
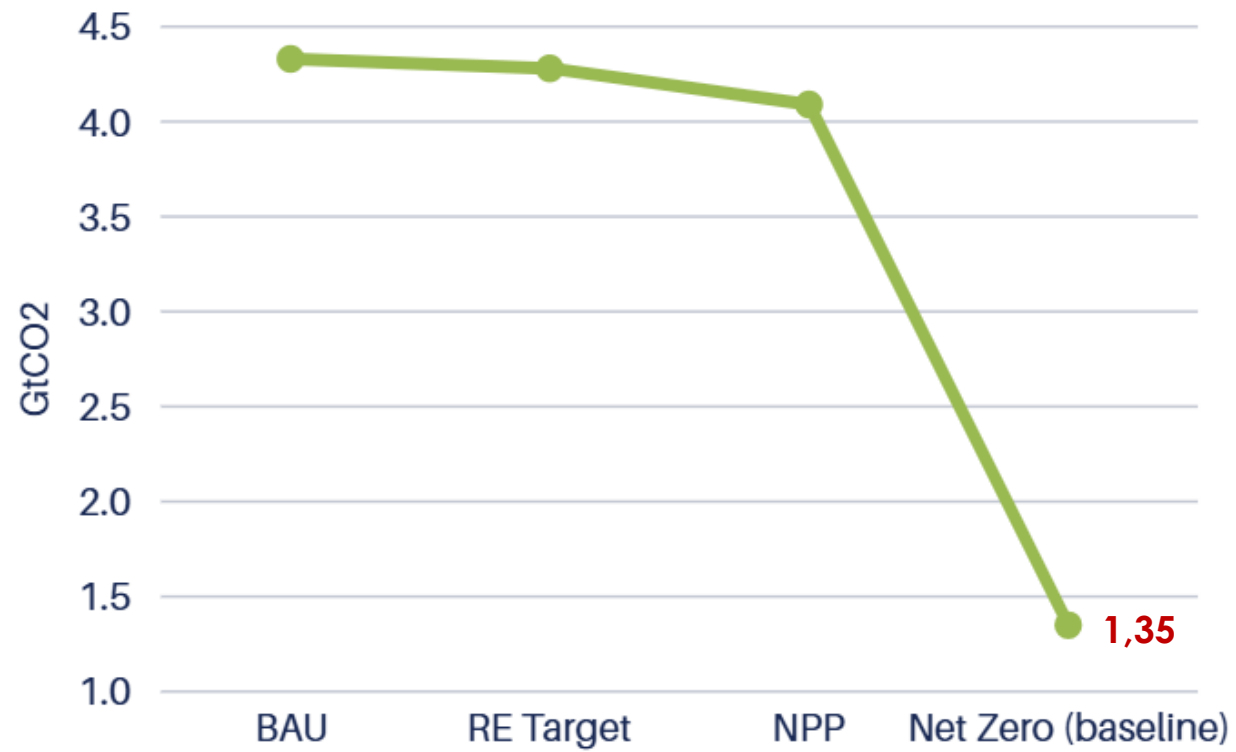

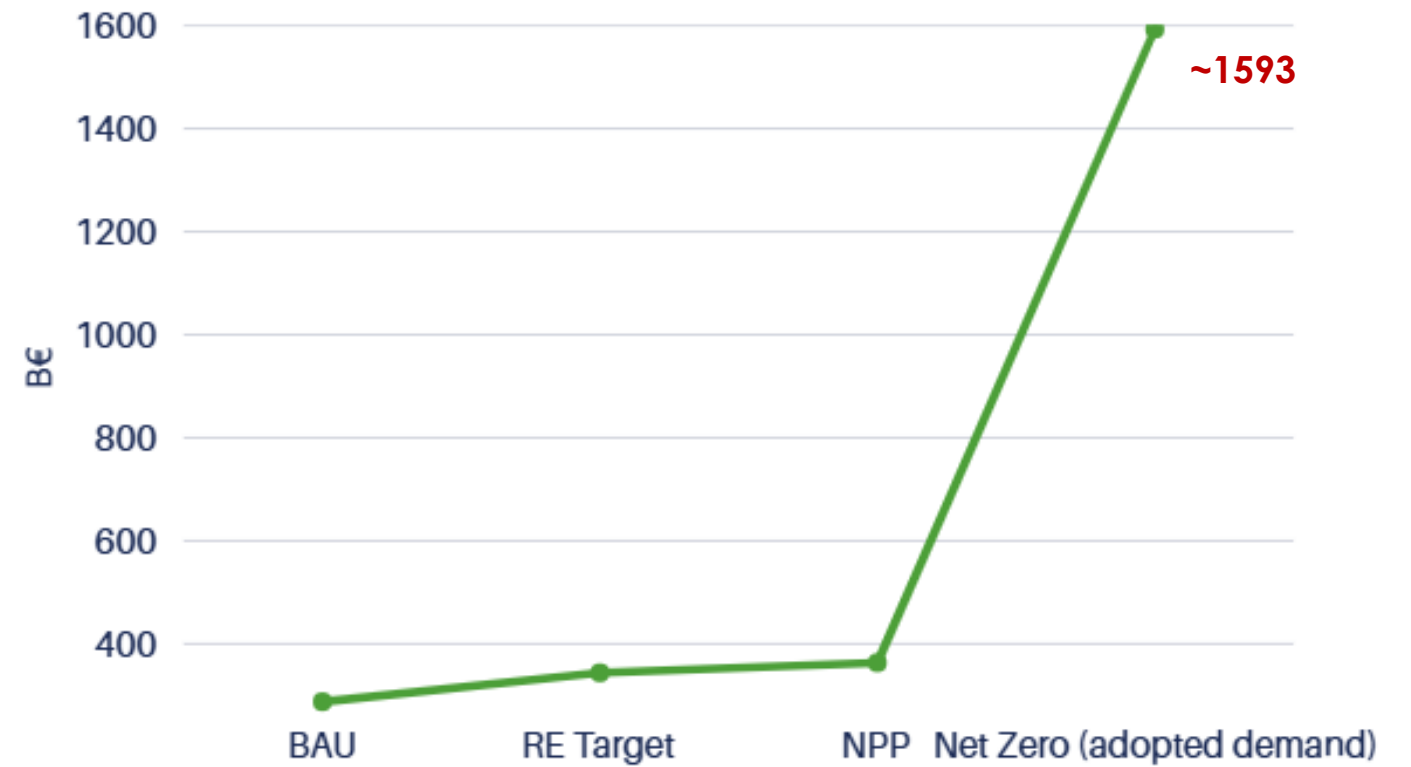
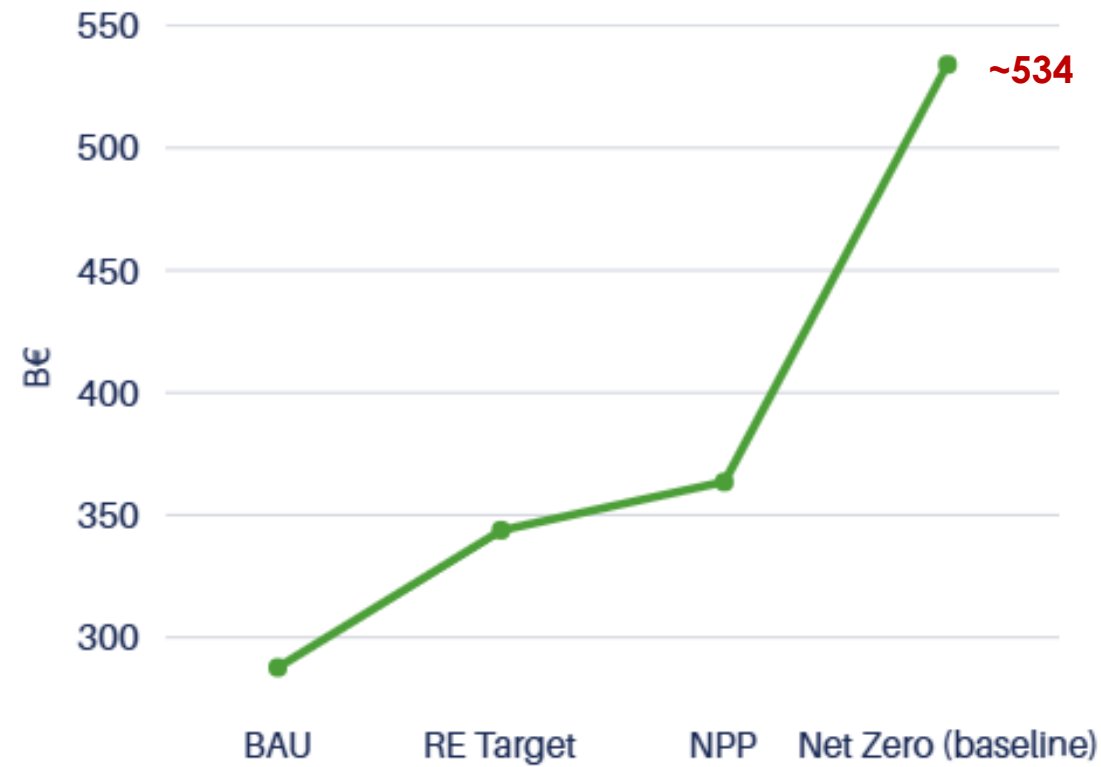

INSIGHT #1

RE is competitive to decrease the coal energy

INSIGHT #2

If to compare first 3 scenarios, the NPP scenario is the most expensive, but also offers lowest emission

INSIGHT #3

The NNP scenario helps to reach 27% RE share by 2060

INSIGHT #4

BAU scenario is the most polluting case

INSIGHT #5

Any push (policy) in the system is leading to a higher cost

INSIGHT #6

The 2035–2045 window is the critical investment period, investment needs peak sharply around 2040 across all scenarios, requiring policymakers to mobilize large-scale financing well in advance to avoid capacity gaps.

INSIGHT #7

To meet Net Zero emission by 2060, there is a big portion of energy that needs to be generated by clean sources. Possible ways that can be a solution are: CCS, integration of BESS...

Conclusions & Next Steps

- More sensitivity analysis
- Stress more the current results to understand model behavior
- Saturate with adding more constraints to make it more realistic
- Investigate more the NZ scenario with more technology options
- Start extending the model into 4 -> 14 node → actual 17 regional nodes
- Expand to include export\import flows between neighboring countries

PyPSA Energy System Model - Kazakhstan

Interactive Model Demonstration

i The BAU scenario is fixed - This demonstration uses the Business As Usual scenario network.

Dispatch Visualization

Select year, month, and week to view one week dispatch data

Year

-- Select Year --

Month

-- Select Month --

Week

-- Select Week --

Select a week (1-4) within the selected month

START DISPATCH

Select year, month, and week to enable the dispatch button

Week

Week 1

Select a week (1-4) within the selected month

START DISPATCH

Select year, month, and week to enable the dispatch button

Dispatch Visualization

One Week Dispatch - 2026 January Week 1

